

this document downloaded from

**vulcanhammer.net**

Since 1997, your complete online resource for information geotechnical engineering and deep foundations:

The Wave Equation Page for Piling

*Online books on all aspects of soil mechanics, foundations and marine construction*

Free general engineering and geotechnical software

*And much more...*

## Terms and Conditions of Use:

All of the information, data and computer software ("information") presented on this web site is for general information only. While every effort will be made to insure its accuracy, this information should not be used or relied on for any specific application without independent, competent professional examination and verification of its accuracy, suitability and applicability by a licensed professional. Anyone making use of this information does so at his or her own risk and assumes any and all liability resulting from such use. The entire risk as to quality or usability of the information contained within is with the reader. In no event will this web page or webmaster be held liable, nor does this web page or its webmaster provide insurance against liability, for any damages including lost profits, lost savings or any other incidental or consequential damages arising from the use or inability to use the information contained within.

This site is not an official site of Prentice-Hall, Pile Buck, the University of Tennessee at Chattanooga, or Vulcan Foundation Equipment. All references to sources of software, equipment, parts, service or repairs do not constitute an endorsement.

**Visit our  
companion site**

**<http://www.vulcanhammer.org>**

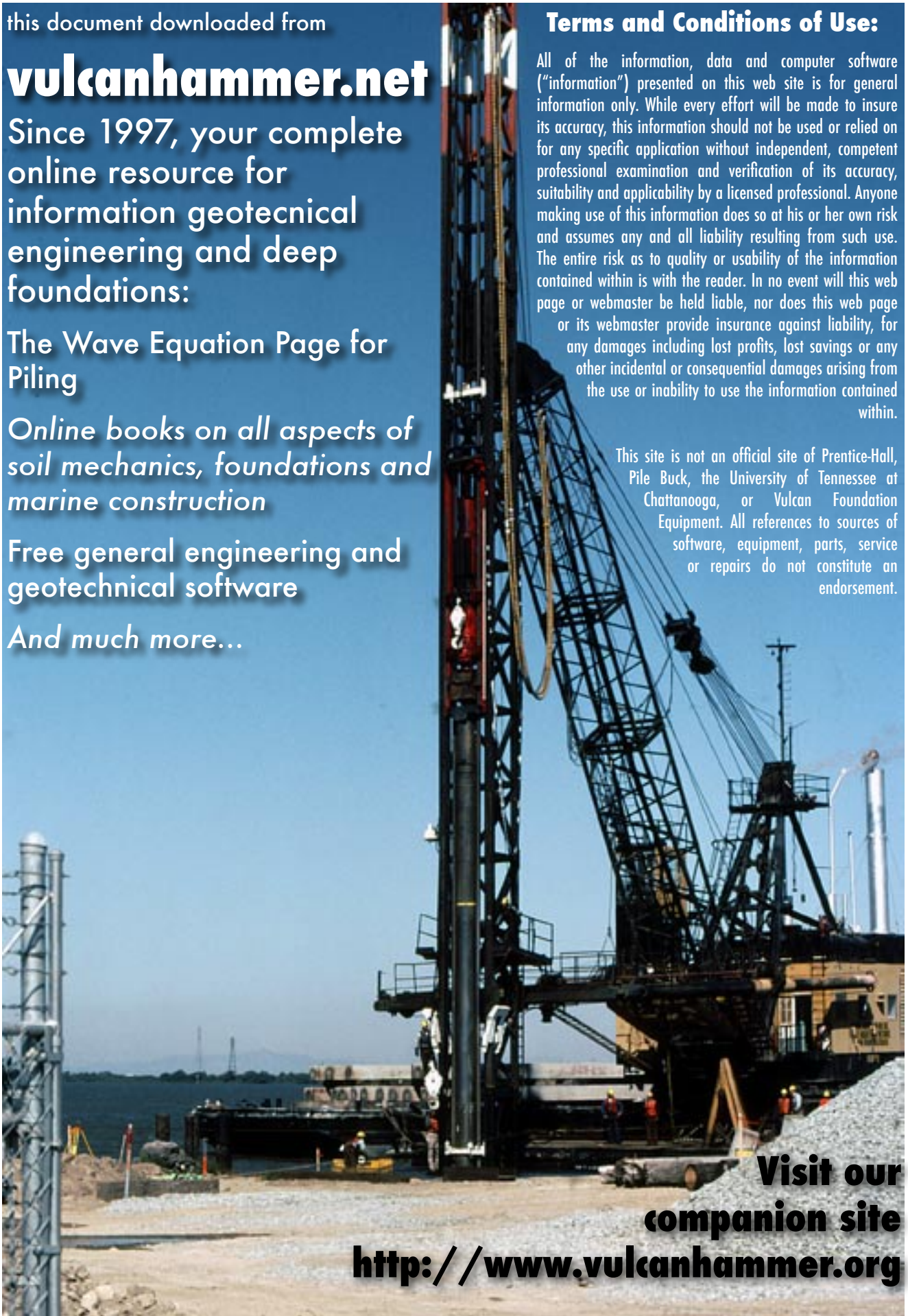

# ENCE 461

## Foundation Analysis and Design

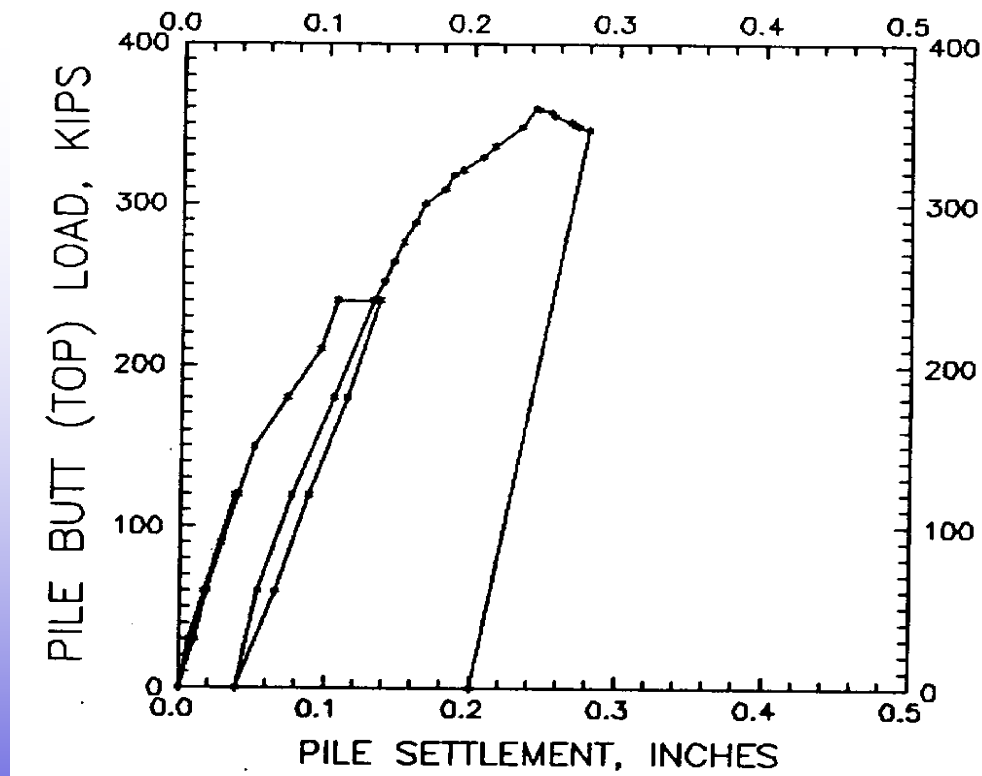

Performance Requirements for Foundations

# Definition of Failure

- “...an unacceptable difference between expected and observed performance.” (G.A. Leonards)
- Foundations are not typically perfectly rigid or unyielding
- They can fail either catastrophically (bearing or shear failure) or by excessive settlement (consolidation, differential settlement, etc.)
- Failure is also dependent on other factors not directly related to the foundation and soil interaction (type of structure, etc.)

# Requirements for Foundation Design

- Strength Requirements
- Serviceability Requirements
- Constructibility Requirements
- Economic Requirements
- Questions to consider
  - How to we deal with uncertainty in loading?
  - How do we deal with combined loads?
  - What is the code environment?
  - How do different foundations respond to different loading?

# Types of Design Loads

- Axial Loads ( $P$ )
- Torsional Loads ( $T$ )
- Moments ( $M_x$ ,  $M_y$ )
- Shear and Lateral Loads ( $V_x$ ,  $V_y$ )

These can in turn help determine the type of foundation to be used.

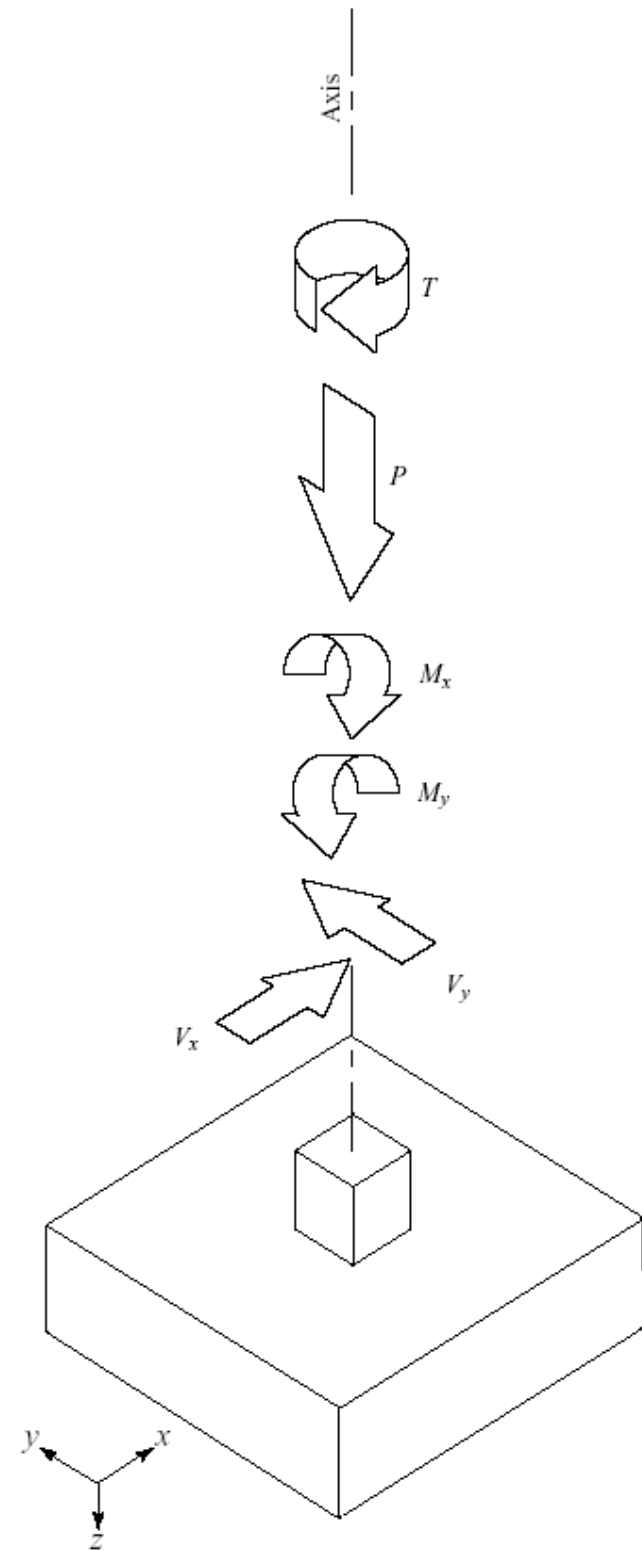

# Types of Foundations to Carry the Loads

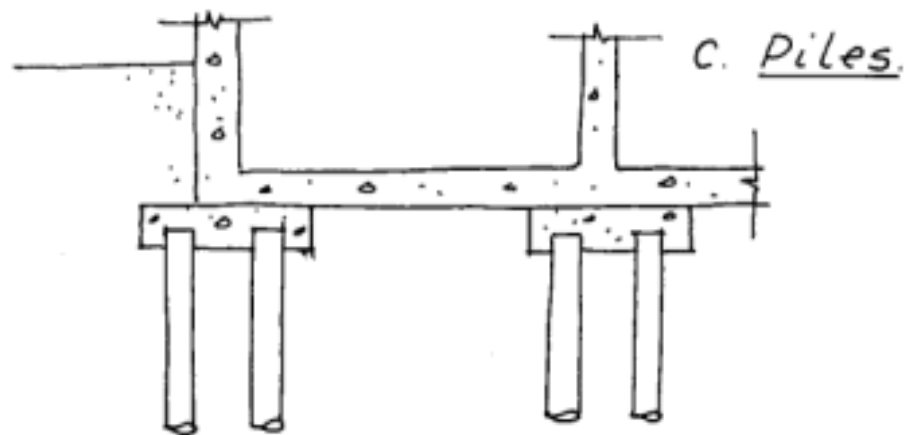
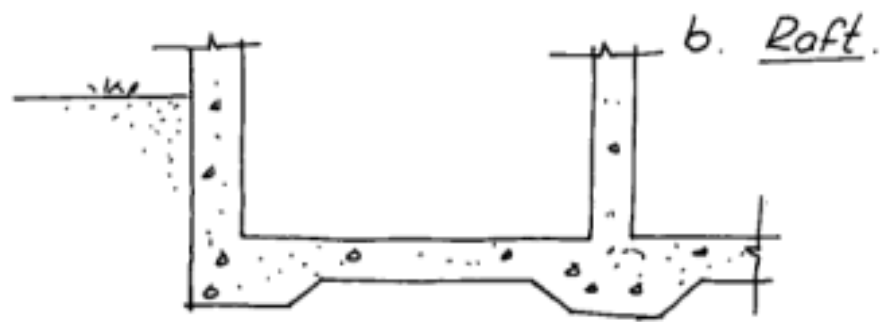

# Sources of Loading

- Dead loads (D)
- Live Loads (L)
- Snow (S) and Rain (R) Loads
- Earth Pressure Loads (H)
- Fluid Loads (F)
- Earthquake Loads (E)
- Wind Loads (W)
- Self-straining loads (S)
- Impact Loads (I)
- Stream Flow (SF) and Ice (ICE) Loads
- Vehicle Motion: Centrifugal (CF) and Braking (BF) Loads

...but how to combine them?

# Method of Expression of Design Load

- **Allowable Stress Design (ASD)**
  - Design load is the most critical combination of the various load sources, as defined by the applicable code
  - The traditional method of geotechnical design
- **Load and Resistance Factor Design (LRFD)**
  - Applies load factors (usually greater than unity) to nominal load to obtain a factored load
  - Factored load is then compared to a resistance factored by its own resistance factor
  - Becoming more important in foundation design

# Notes on Design Codes

- Codes chosen in this course are primarily for example purposes
- The applicability of any given code will vary from project to project, so make sure you are referring to the correct code when designing
- Adherence to a building or design code is NOT a guarantee that your design is correct, safe, or constructible.
- Adherence to a code is not a substitute for proper engineering judgment

# Allowable Stress Design

- ANSI/ASCE (*Minimum Design Loads for Buildings and Other Structures*) criteria for most critical combination of the various load sources: greatest of the following:

$$D$$

$$D + L + F + H + T + (L_r \vee S \vee R)$$

$$D + L + (L_r \vee S \vee R) + (W \vee E)$$

$$D + (W \vee E)$$

# Allowable Stress Design

- Alternative Method of Evaluation Wind and Seismic Loads (IBC, UBC, BOCA)

$$0.75 [D + L + (L_r \vee S \vee R) + (W \vee E)]$$
$$0.75 [D + (W \vee E)]$$

- Substitute for last two equations in previous slide
- Enables foundation to be sized only once rather than for wind and seismic loads separately

# Example of ASD Design

- Given
  - Column carries following vertical compressive loads:
    - $P_D$  (D) = 2100 kN Downward (Dead Load)
    - $P_L$  (L) = 1400 kN Downward (Live Load)
    - $P_W$  (W) = 600 kN Upward (Wind Load)
- Find
  - Compute normal design load for use in foundation design using ASD load combinations

# Example of ASD Design

- Governing Equations (ANSI/ASCE)

$D$

$$D + L + F + H + T + (L_r \vee S \vee R)$$
$$0.75 [D + L + (L_r \vee S \vee R) + (W \vee E)]$$
$$0.75 [D + (W \vee E)]$$

- $D = 2100 \text{ kN}$
- $L = 1400 \text{ kN}$
- $W = -600 \text{ kN}$  (note sign convention)

# Example of ASD Design

- Substituting Variables

$$2100 \text{ kN}$$

$$2100 + 1400 + 0 + 0 + 0 + 0 = 3500 \text{ kN}$$

$$\frac{3}{4} [2100 + 1400 + 0 - 600] = 2175 \text{ kN}$$

$$\frac{3}{4} [2100 - 600] = 1125 \text{ kN}$$

- 3500 kN is the governing load

# “Typical” Factors of Safety

Factor of safety, F

$$F = \frac{\sum \text{Forces preventing failure}}{\sum \text{Forces initiating failure}}$$

$$F = \frac{\sum \text{Moments preventing failure}}{\sum \text{Moments initiating failure}}$$

Type	F
Dams, fills	1.2 - 1.6
Retaining walls	1.5 - 2.0
Sheet pile walls and coffer dams	1.2 - 1.6
Braced excavations	1.2 - 1.5
Footings	2 - 3
Mats, rafts	1.7 - 2.5
Uplift, heave	1.5 - 2.5
Piping	3 - 5

# Example of Application of Factors of Safety

- Given
  - Previous problem, 3500 kN design load
- Find
  - Ultimate Downward Capacity, FS = 2
- Solution
  - $P_u = (P)(FS) = (3500 \text{ kN})(2) = 7000 \text{ kN}$
  - Primarily applicable to the resisting capacity of the soil rather than the material capacity of the foundation material

# Example Applied to Material Sizing

- Given
  - Foundation with design load of 3500 kN
  - To be supported by four (4) H-piles, made of A 36 steel
    - Yield Strength = 36 ksi
    - Allowable Strength = 10 ksi = 69 MPa = 69,000 kPa
  - Eccentricity and bending not taken into consideration; purely axial load
- Find
  - Required cross-sectional area of steel

# H-Piles



# Eccentricity of Load

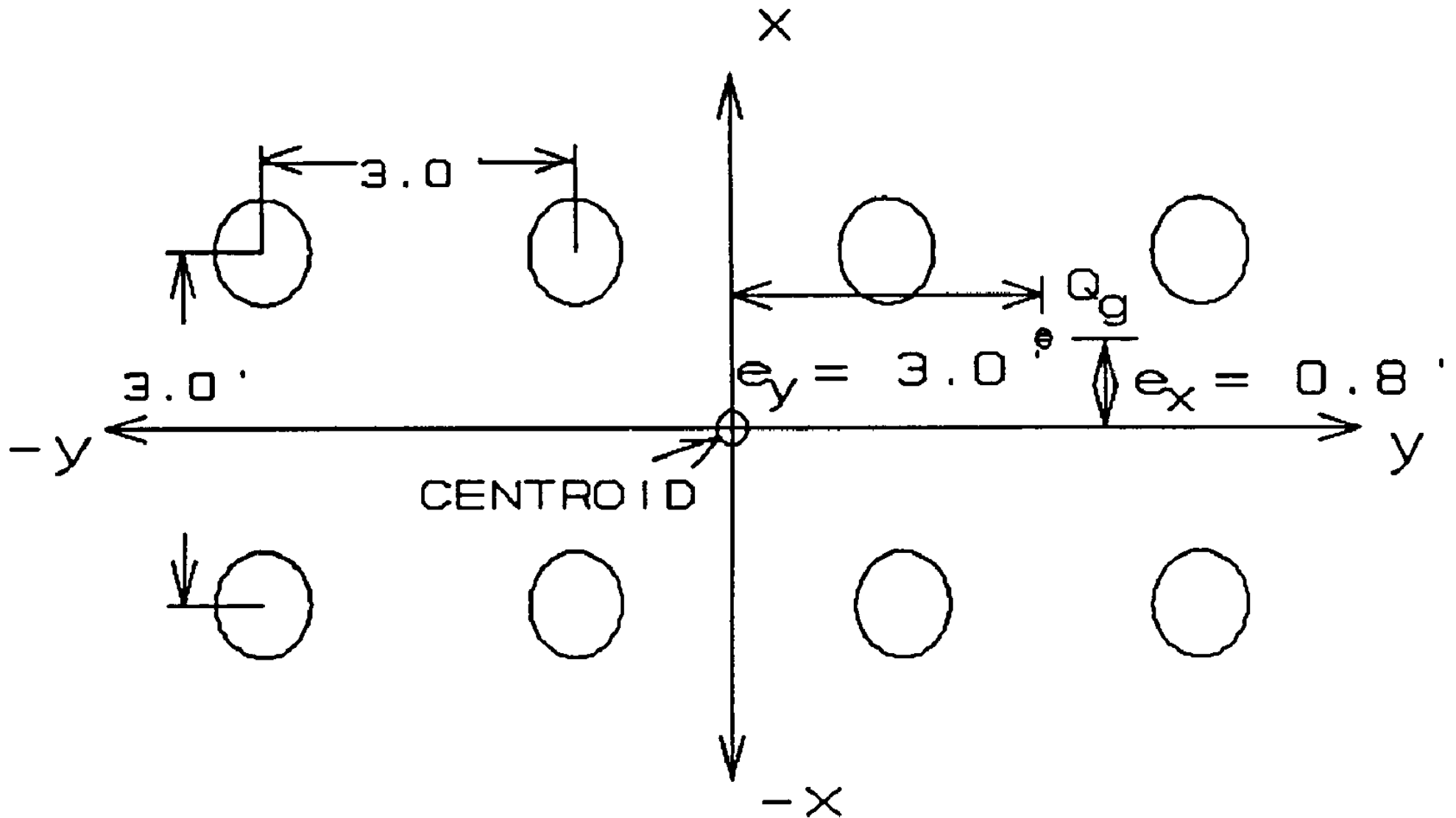

# Computation of Cross-Sectional Area

- Load Divided among the four H-beams
  - $P/\text{pile} = 3500 \text{ kN}/4 = 875 \text{ kN}$
- Computation of cross-sectional area per pile based on allowable stresses
  - $A = \text{Load}/\text{Allowable Stress} = 875 \text{ kN}/69,000 \text{ kPa} = 0.01268 \text{ m}^2 = 12,681 \text{ mm}^2 = 19.66 \text{ in}^2$
- Select H-Beam Size Based on H-Beam Tables

# H-Beam Tables

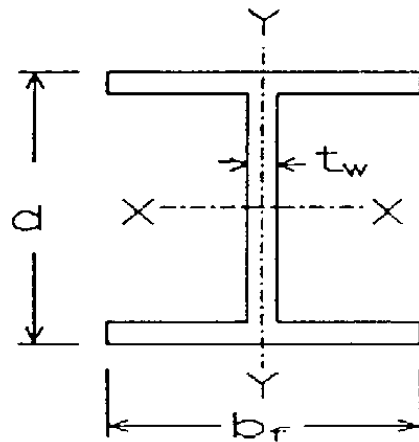

I = MOMENT OF INERTIA, IN.<sup>4</sup>, mm<sup>4</sup>  
 S = SECTION MODULUS, IN.<sup>3</sup>, mm<sup>3</sup>  
 r = RADIUS OF GYRATION, IN., mm

Area = 12,681 mm<sup>2</sup> = 19.66 in<sup>2</sup>

## a. English Units

Designation	Area A, in. <sup>2</sup>	Depth d, in.	Flange		Web Thickness t <sub>w</sub> , in.	Section Properties					
			Width b <sub>f</sub> , in.	Thickness t <sub>f</sub> , in.		Axis X-X			Axis Y-Y		
						I, in. <sup>4</sup>	S, in. <sup>3</sup>	r, in.	I, in. <sup>4</sup>	S, in. <sup>3</sup>	r, in.
HP14 x 117	34.4	14.21	14.885	0.805	0.805	1220	172.0	5.96	443.0	59.5	3.59
x 102	30.0	14.01	14.785	0.705	0.705	1050	150.0	5.92	380.0	51.4	3.56
x 89	26.1	13.83	14.695	0.615	0.615	904	131.0	5.88	326.0	44.3	3.53
x 73	21.4	13.61	14.585	0.505	0.505	729	107.0	5.84	261.0	35.8	3.49
HP13 x 100	29.4	13.15	13.205	0.765	0.765	886	135.0	5.49	294.0	44.5	3.16
x 87	25.5	12.95	13.105	0.665	0.665	775	117.0	5.45	250.0	38.1	3.13
x 73	21.6	12.75	13.005	0.565	0.565	630	98.8	5.40	207.0	31.9	3.10
x 60	17.5	12.54	12.900	0.460	0.460	503	80.3	5.36	165.0	25.5	3.07
HP12 x 84	24.6	12.28	12.295	0.685	0.685	650	106.0	5.14	213.0	34.6	2.94
x 74	21.8	12.13	12.215	0.610	0.610	569	93.8	5.11	186.0	30.4	2.92
x 63	18.4	11.94	12.125	0.515	0.515	472	79.1	5.06	153.0	25.3	2.88
x 53	15.5	11.78	12.045	0.435	0.435	393	66.8	5.03	127.0	21.1	2.86
HP10 x 57	16.8	9.99	10.225	0.565	0.565	294	58.8	4.18	101.0	19.7	2.45
x 42	12.4	9.70	10.075	0.420	0.420	210	43.4	4.13	71.7	14.2	2.41
HP8 x 36	10.6	8.02	8.155	0.445	0.445	119	29.8	3.36	40.3	9.86	1.95

# H-Beam Tables

$$\text{Area} = 12,681 \text{ mm}^2 = 19.66 \text{ in}^2$$

## b. Metric Units

Designation	Area $A, \text{mm}^2$	Depth $d, \text{mm}$	Flange		Web	Section Properties					
			Width $b_f, \text{mm}$	Thickness $t_f, \text{mm}$	Thickness $t_w, \text{mm}$	Axis X-X			Axis Y-Y		
						$I, 10^6 \text{mm}^4$	$S, 10^3 \text{mm}^3$	$r, \text{mm}$	$I, 10^6 \text{mm}^4$	$S, 10^3 \text{mm}^3$	$r, \text{mm}$
HP360 x 174	22200	361	378	20.4	20.4	504	2810	151	184	974	91.0
x 152	19400	356	376	17.9	17.9	439	2470	150	159	846	90.5
x 132	16900	351	373	15.6	15.6	375	2140	149	135	724	89.4
→ x 108	13800	346	370	12.8	12.8	303	1750	148	108	584	88.5
HP330 x 149	19000	334	335	19.4	19.4	368	2200	139	122	728	80.1
x 129	16400	329	333	16.9	16.9	315	1910	139	104	625	79.6
→ x 109	13900	324	330	14.4	14.4	263	1620	138	86.3	523	78.8
x 89	11300	319	328	11.7	11.7	211	1320	137	68.9	420	78.1
HP310 x 125	15900	312	312	17.4	17.4	270	1730	130	88.2	565	74.5
→ x 110	14100	308	310	15.5	15.4	237	1540	130	77.1	497	73.9
x 93	11900	303	308	13.1	13.1	196	1290	128	63.9	415	73.3
x 79	10000	299	306	11.0	11.0	163	1090	128	52.6	344	72.5
HP250 x 85	10800	254	260	14.4	14.4	123	969	107	42.3	325	62.6
x 62	7970	246	256	10.7	10.5	87.5	711	105	30.0	234	61.4
HP200 x 53	6820	204	207	11.3	11.3	49.8	488	85.5	16.7	161	49.5

# Load and Resistance Factor Design (LRFD)

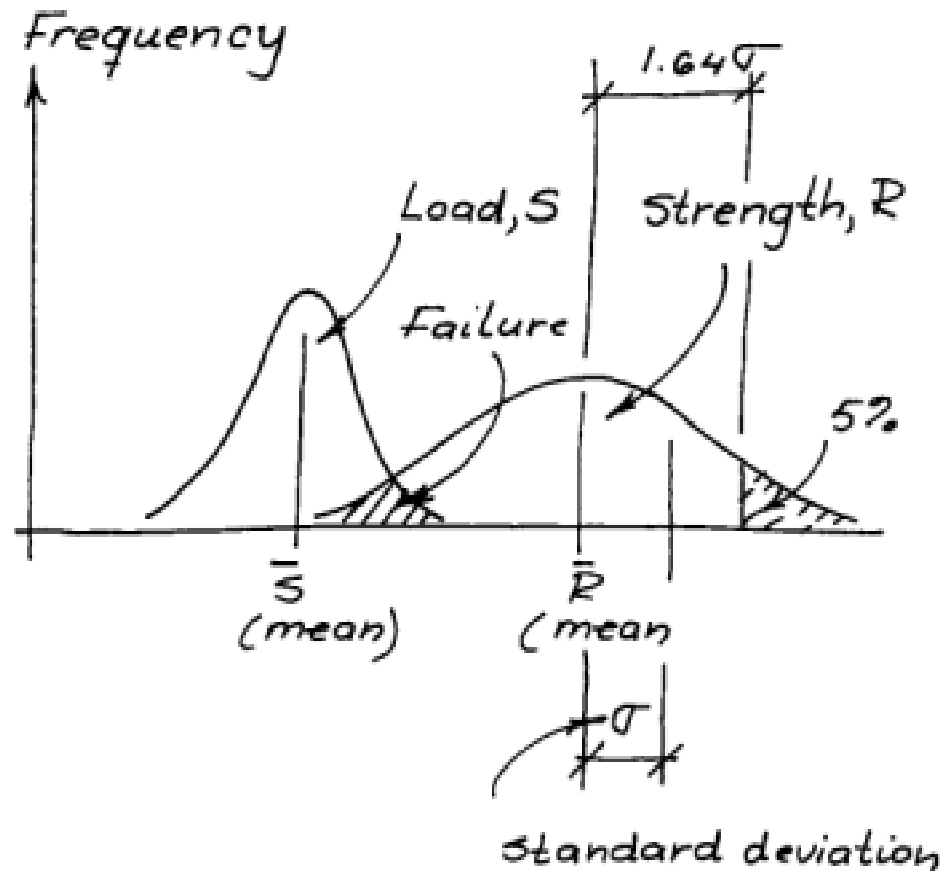

$\frac{P}{R} = \text{Coefficient of variation}$

$\bar{R} = \text{Mean value}$

# LRFD Governing Equation

$$\phi P_n \geq \sum_{i=1}^m \gamma_m P_m$$

- $\phi$  = resistance factor
- $P_n$  = nominal normal load capacity
- $\gamma_m$  = load factor for load “type” m
- $P_m$  = load for load “type” m
- m = load “type”: dead (D), live (L), etc.

# Load Factors for...

Dead loads

Live loads

Wind loads

Earth quake loads

Load factors

# Implementations of LRFD

- Load Factor Implementations
  - American Concrete Institute (ACI) Code
  - ANSI/ASCE and AISC Codes
  - AASHTO Code
- Resistance Factor Implementations
  - PDCA Proposal (Driven Piles)
  - AASHTO Resistance Factors
  - FHWA (for drilled shafts)
  - Electric Power Research Institute (EPRI)

# ACI Code – Factored Load

$$U = 1.4D + 1.7L$$

$$U = 0.75 (1.4D + 1.4T + 1.7L)$$

$$U = 0.9D + 1.4F$$

$$U = 1.4D + 1.7L + 1.4F$$

$$U = 1.4D + 1.7L + 1.7H$$

$$U = 0.9D + 1.3W$$

$$U = 0.9D + 1.43 E$$

$$U = 0.75 (1.4D + 1.7L + 1.7W)$$

$$U = 0.75 (1.4D + 1.7L + 1.87 E)$$

$$U = 0.9D + 1.7H$$

$$U = 1.4 (D + T)$$

# ANSI/ASCE Codes – Factored Load

$$U = 1.4D$$

$$U = 1.2(D + F + T) + 1.6(L + H) \\ + 0.5(L_r \vee S \vee R)$$

$$U = 1.2D + 1.6(L_r \vee S \vee R) + (0.5L \vee 0.8W)$$

$$U = 1.2D + 1.3W + 0.5L + 0.5(L_r \vee S \vee R)$$

$$U = 1.2D + E + 0.5L + 0.2S$$

$$U = 0.9D + (1.3W \vee 1.0E)$$

# Example of LRFD Design

- Given
  - Column carries following vertical compressive loads:
    - $P_D$  (D) = 2100 kN Downward (Dead Load)
    - $P_L$  (L) = 1400 kN Downward (Live Load)
    - $P_W$  (W) = 600 kN Upward (Wind Load)
- Find
  - Compute normal design load for use in foundation design using ANSI/ASCE load factors and PDCA structural resistance factors
  - Compute Cross-Sectional Area for A-36 H-piles

# Computation of Factored Load

$$U = (1.4)(2100) = 2940 \text{ kN}$$

$$U = 1.2(2100) + 1.6(1400) = 4760 \text{ kN}$$

$$U = 1.2(2100) + (0.5(1400) \vee 0.8(-600)) = 2380 \text{ kN}$$

$$U = 1.2(2100) + 1.3(-600) + 0.5(1400) = 2440 \text{ kN}$$

$$U = 1.2(2100) + 0.5(1400) = 2380 \text{ kN}$$

$$U = 0.9(2100) + (1.3(-600) \vee 1.0(0)) = 1890 \text{ kN}$$

# Factored Load and Resistance Per Pile

- Factored Load Per Pile =  $4760 \text{ kN}/4 = 1190 \text{ kN}$

$$\phi P_n \geq 1190 \text{ kN}$$

$$P_n = \frac{1190 \text{ kN}}{\phi}$$

- Need to determine  $\phi$  using PDCA recommendations (always know applicable code!)

# PDCA Structural Resistance Factors

Pile Material	Using ACI Load Factors	Using ANSI Load Factors
Timber	0.6	0.55
Steel	0.95	0.85
Prestressed Concrete with Spiral Reinforcement that Satisfies the ACI code	0.75	0.7
Prestressed Concrete with other types of transverse reinforcement	0.7	0.65

# Solution for Normal Load and Cross-Sectional Area

- Normal Load

$$\phi P_n \geq 1190 \text{ kN}$$



$$P_n = \frac{1190 \text{ kN}}{0.85} = 1400 \text{ kN}$$

- Area = (1400 kN)/(248,000 kPa) = 0.00564 m<sup>2</sup> = 5,645 mm<sup>2</sup> (note use of full yield strength of material)
- Solution with ASD method = 12,681 mm<sup>2</sup>

# Selection of H-Beam

Any H-beam meet the criteria. Red arrows: ASD suitable H-beams

## b. Metric Units

Designation	Area $A, \text{mm}^2$	Depth $d, \text{mm}$	Flange		Web	Section Properties					
			Width $b_f, \text{mm}$	Thickness $t_f, \text{mm}$	Thickness $t_w, \text{mm}$	Axis X-X			Axis Y-Y		
						$I, 10^6 \text{mm}^4$	$S, 10^3 \text{mm}^3$	$r, \text{mm}$	$I, 10^6 \text{mm}^4$	$S, 10^3 \text{mm}^3$	$r, \text{mm}$
HP360 x 174	22200	361	378	20.4	20.4	504	2810	151	184	974	91.0
x 152	19400	356	376	17.9	17.9	439	2470	150	159	846	90.5
x 132	16900	351	373	15.6	15.6	375	2140	149	135	724	89.4
 x 108	13800	346	370	12.8	12.8	303	1750	148	108	584	88.5
HP330 x 149	19000	334	335	19.4	19.4	368	2200	139	122	728	80.1
x 129	16400	329	333	16.9	16.9	315	1910	139	104	625	79.6
 x 109	13900	324	330	14.4	14.4	263	1620	138	86.3	523	78.8
x 89	11300	319	328	11.7	11.7	211	1320	137	68.9	420	78.1
HP310 x 125	15900	312	312	17.4	17.4	270	1730	130	88.2	565	74.5
 x 110	14100	308	310	15.5	15.4	237	1540	130	77.1	497	73.9
x 93	11900	303	308	13.1	13.1	196	1290	128	63.9	415	73.3
x 79	10000	299	306	11.0	11.0	163	1090	128	52.6	344	72.5
HP250 x 85	10800	254	260	14.4	14.4	123	969	107	42.3	325	62.6
x 62	7970	246	256	10.7	10.5	87.5	711	105	30.0	234	61.4
HP200 x 53	6820	204	207	11.3	11.3	49.8	488	85.5	16.7	161	49.5

# Strength Requirements

- Geotechnical Strength Requirements
  - Design to prevent failure by soil shear failure
  - Geotechnical strength for shear failure is referred to as the *bearing capacity* of the soil
  - Analysis usually performed by ASD analysis; LRFD becoming more common
- Structural Strength Requirements
  - Design to avoid structural failure of foundation components
  - Similar to other structural analyses

# Bearing Capacity Failure

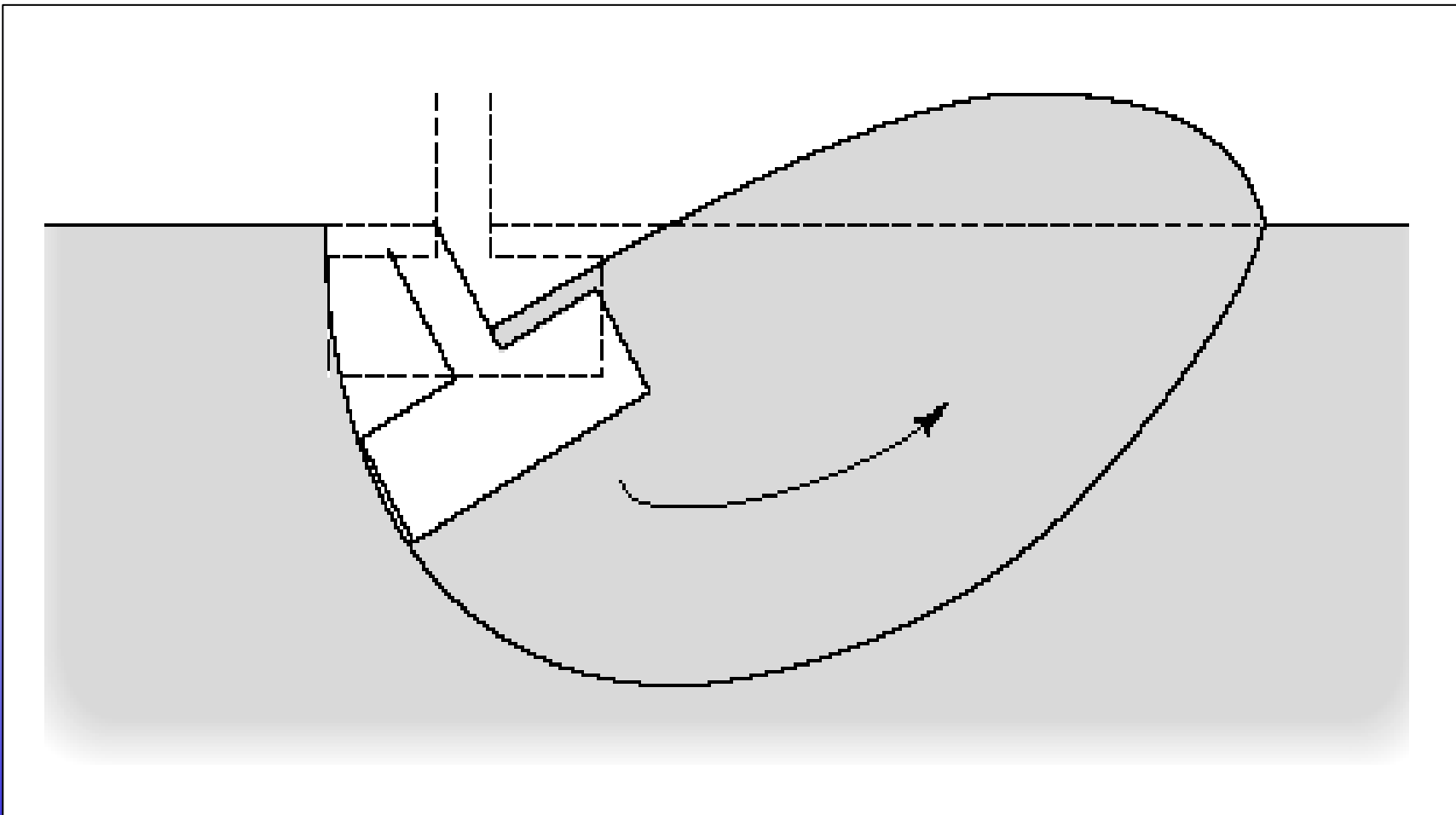

# Serviceability Considerations

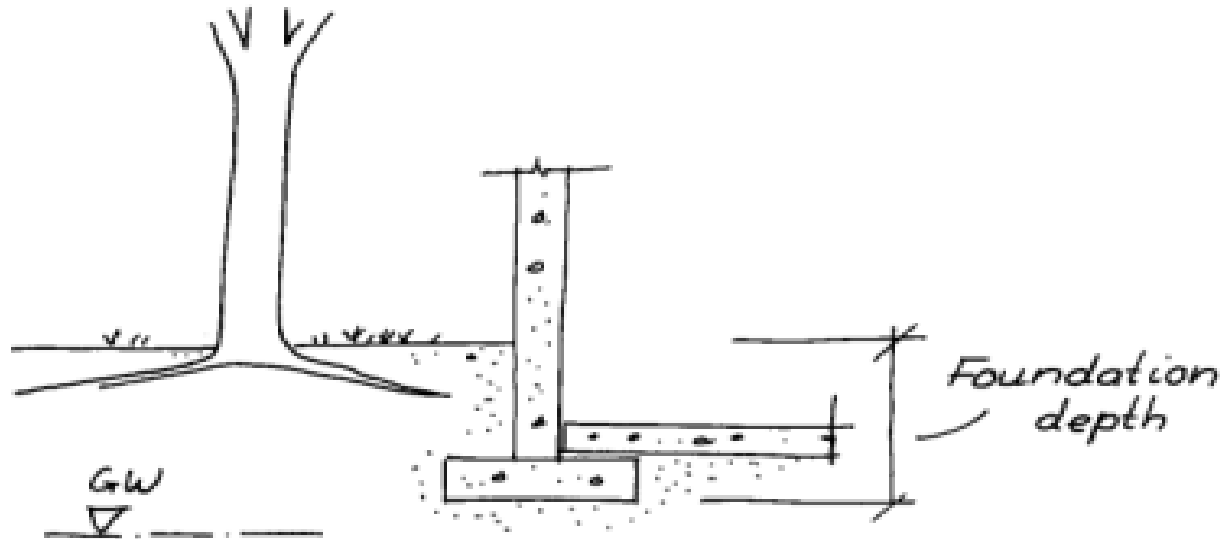

## Design considerations.

1. Seasonal changes (wet and dry periods)
2. Frost heave
3. Change of ground water level
4. Internal erosion (piping)
5. Adjacent excavations and buildings
6. Soil creep
7. Sinkholes (karst)
8. Vibrations
9. Deterioration of concrete (sulphate)

# Settlement of Structures

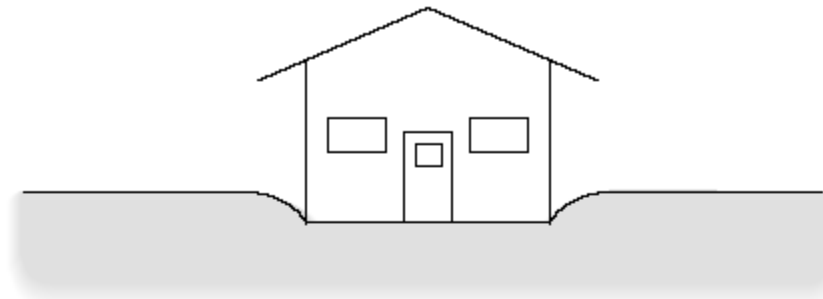

(a)

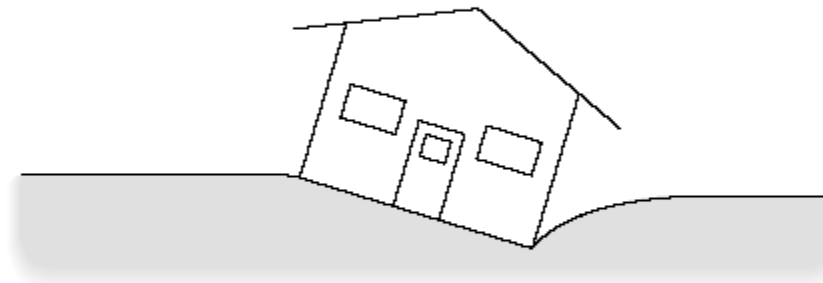

(b)



(c)

# Total Settlement

Change in Foundation elevation from the original unloaded position to the final loaded position

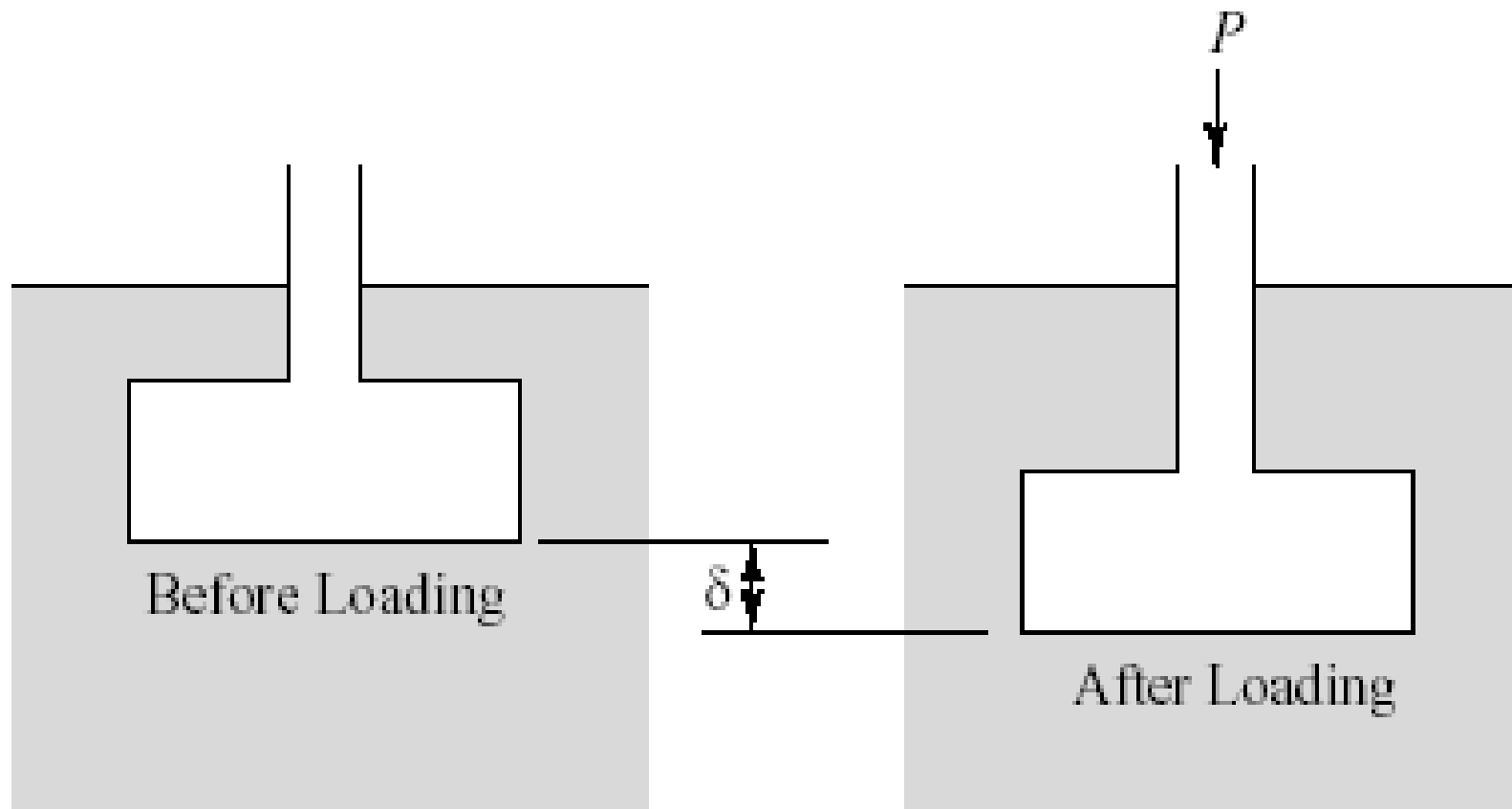

# Factors to Determine Acceptable Settlement

- Connections with existing structures
- Utility Lines
  - Total settlement of permanent facilities can harm or sever connections to outside utilities such as water, natural gas, and sewer lines. Water and sewer lines may leak contributing to localised wetting of the soil profile and aggravating differential displacement. Leaking gas from breaks caused by settlement can lead to explosions.
- Surface Drainage
- Access
- Aesthetics

# “Typical” Values of Acceptable Settlement

Maximum Allowable Average Settlement of Some Structures

(Data from Item 53)

<u>Type of Structure</u>	<u>Settlement, inches</u>
Plain brick walls	
Length/Height $\geq 2.5$	3
Length/Height $\leq 1.5$	4
Framed structure	4
Reinforced brick walls and brick walls with reinforced concrete	6
Solid reinforced concrete foundations supporting smokestacks, silos, towers, etc	12

# Differential Settlement

- Differential settlement, which causes distortion and damages in structures, is a function of the:
  - uniformity of the soil
  - stiffness of the structure
  - stiffness of the soil
  - distribution of loads within the structure.
- Limitations to differential settlement depend on the application. Differential settlements should not usually exceed  $\frac{1}{2}$ " (13 mm) in buildings, otherwise cracking and structural damage may occur.

# Distortion of Foundations

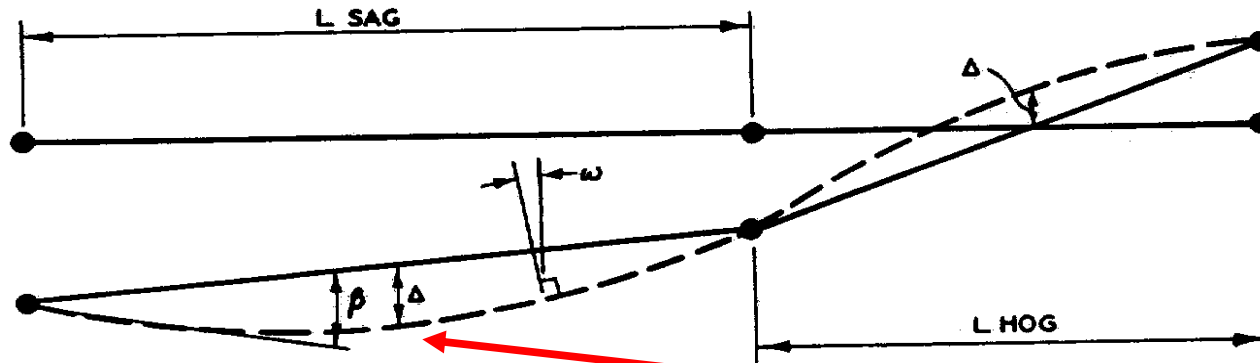

a. COMBINATION  $L_{SAG}$  AND  $L_{HOG}$

Angular Distortion

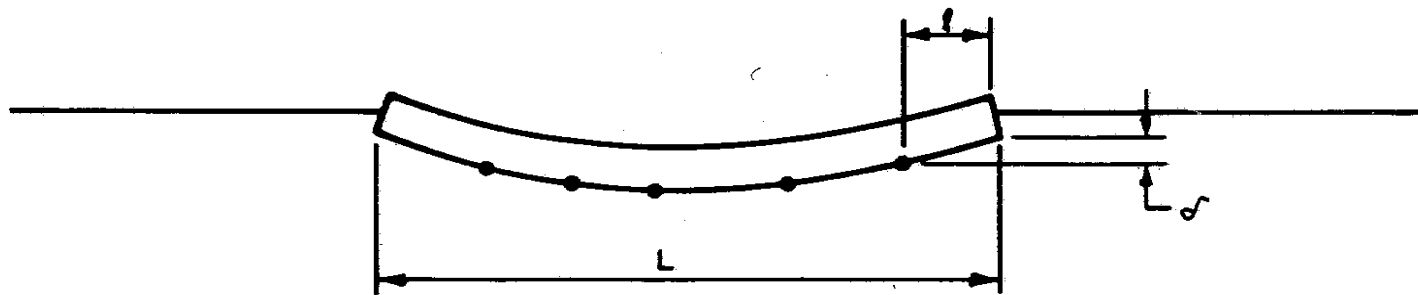

b. REGULAR SETTLEMENT

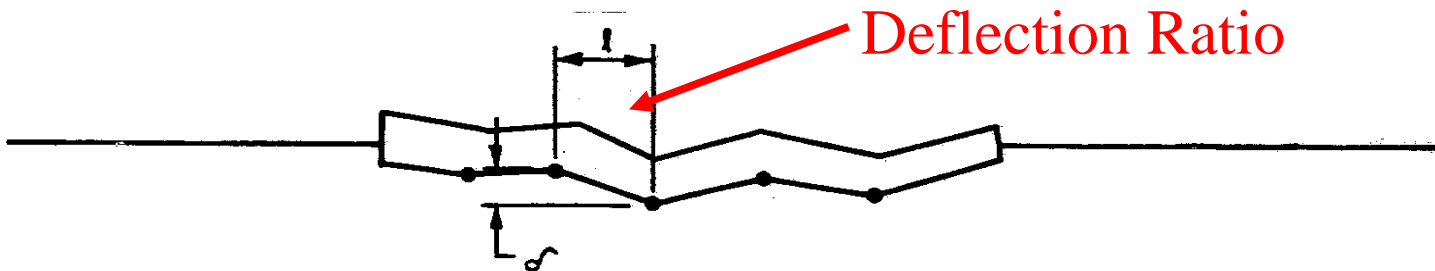

Deflection Ratio

c. IRREGULAR SETTLEMENT

# Allowable Deflection Ratio

Some Limiting Deflection Ratios  
(After Items 17, 53, 65)

<u>Structure</u>	<u>Deflection Ratio, <math>\Delta/L</math></u>	
	<u>Sand and Hard Clay</u>	<u>Plastic Clay</u>
Buildings with plain brick walls		
Length/Height $\geq 3$	1/3333	1/2500
Length/Height $\geq 5$	1/2000	1/1500
One story mills; between columns for brick clad column frames	1/1000	1/1000
Steel and concrete frame	1/500	1/500

# Allowable Angular Distortion

Limiting Angular Distortions to Avoid  
Potential Damages (Data from Items 53, 65, TM 5-818-1)

<u>Situation</u>	<u>Length Height</u>	<u>Allowable Angular Distortion, <math>\beta = \delta/L</math></u>
Hogging of unreinforced load-bearing walls		1/2000
Load bearing brick, tile, or concrete block walls	$\geq 5$ $\leq 3$	1/1250 1/2500
Sagging of unreinforced load-bearing walls		1/1000
Machinery sensitive to settlement		1/750
Frames with diagonals		1/600
No cracking in buildings; tilt of bridge abutments; tall slender structures such as stacks, silos, and water tanks on a rigid mat		1/500
Steel or reinforced concrete frame with brick, block, plaster or stucco finish	$\geq 5$ $\leq 3$	1/500 1/1000
Circular steel tanks on flexible base with floating top; steel or reinforced concrete frames with insensitive finish such as dry wall, glass, panels		1/300 - 1/500
Cracking in panel walls; problems with overhead cranes		1/300
Tilting of high rigid buildings		1/250
Structural damage in buildings; flexible brick walls with length/height ratio $> 4$		1/150
Circular steel tanks on flexible base with fixed top; steel framing with flexible siding		1/125

# Example of Settlement Calculations

- Given
  - Steel framed office building, 20' column spacing
  - Supported on spread footings founded on clayey soil
- Find
  - Allowable total settlement
  - Allowable differential settlement
- Solution
  - Typical total settlement specification = 1"
  - Use  $\delta = 1/500$ ;  $\delta_{du} = (1/500)(20') = 0.04' = 0.5''$

# Settlement vs. Bearing Capacity

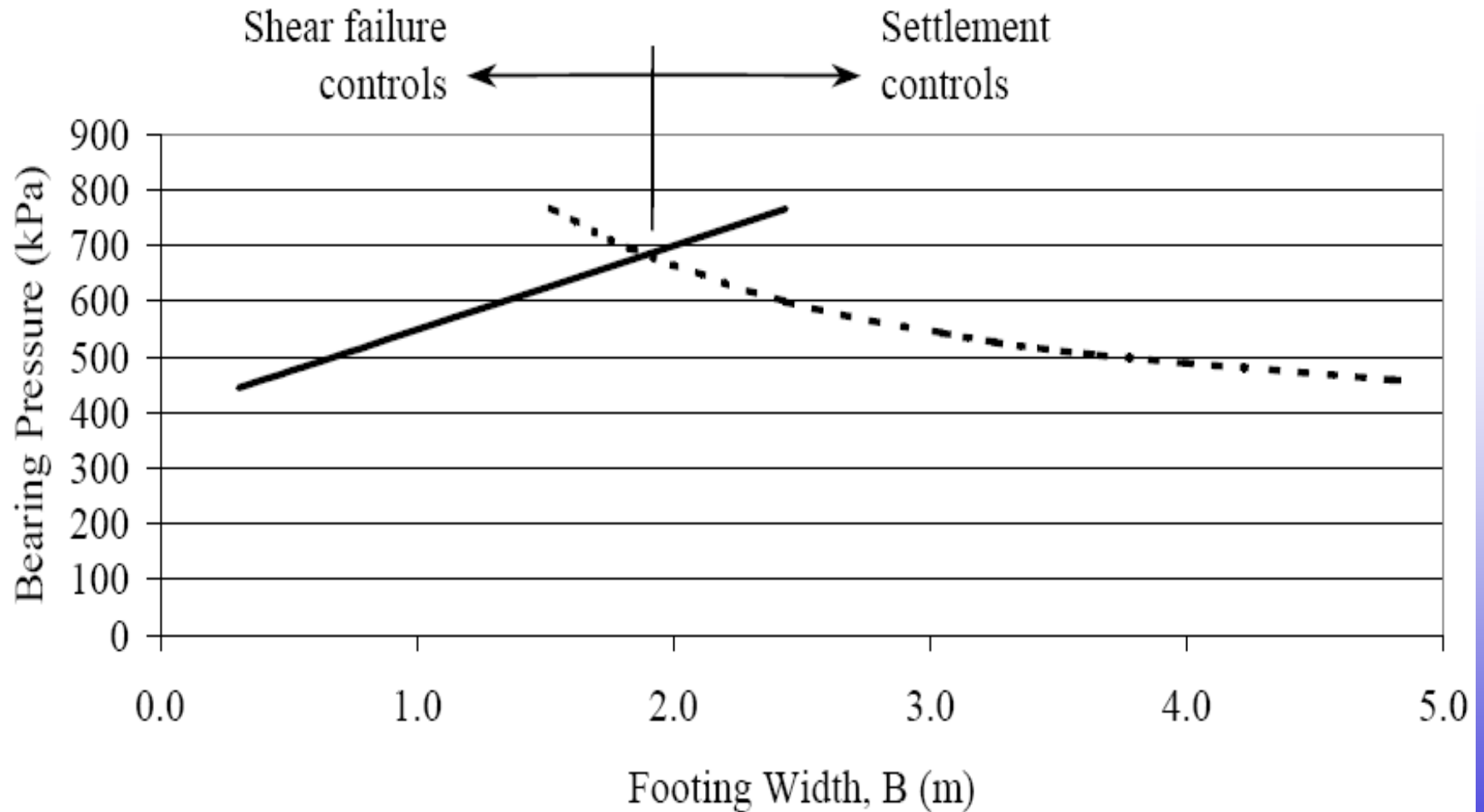

- Allowable Bearing Capacity (FS = 3.0)
- - - Bearing Pressure for 25-mm (1 in) Settlement

# Interaction of Neighbouring Structures

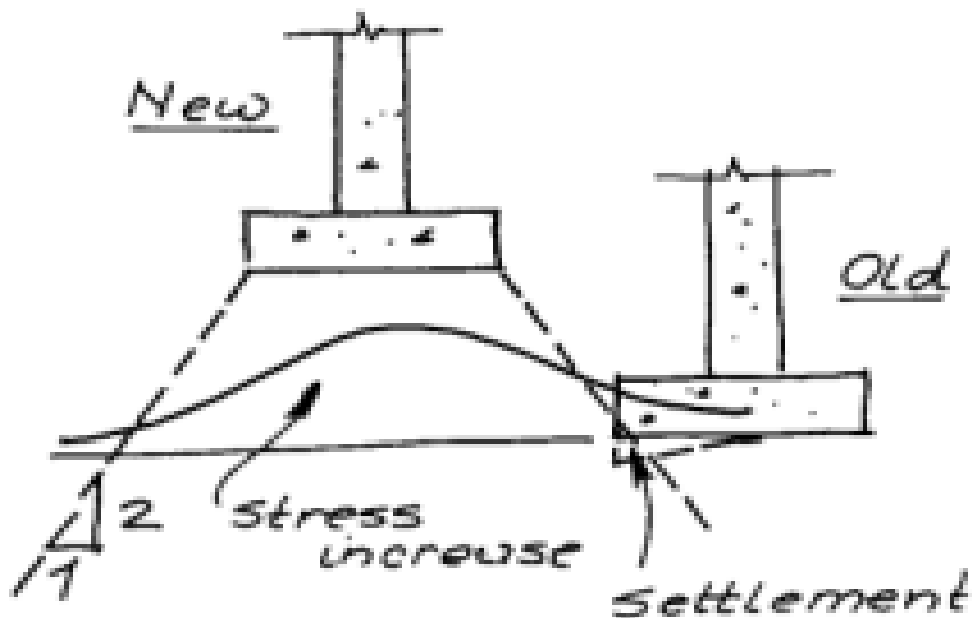

(a)

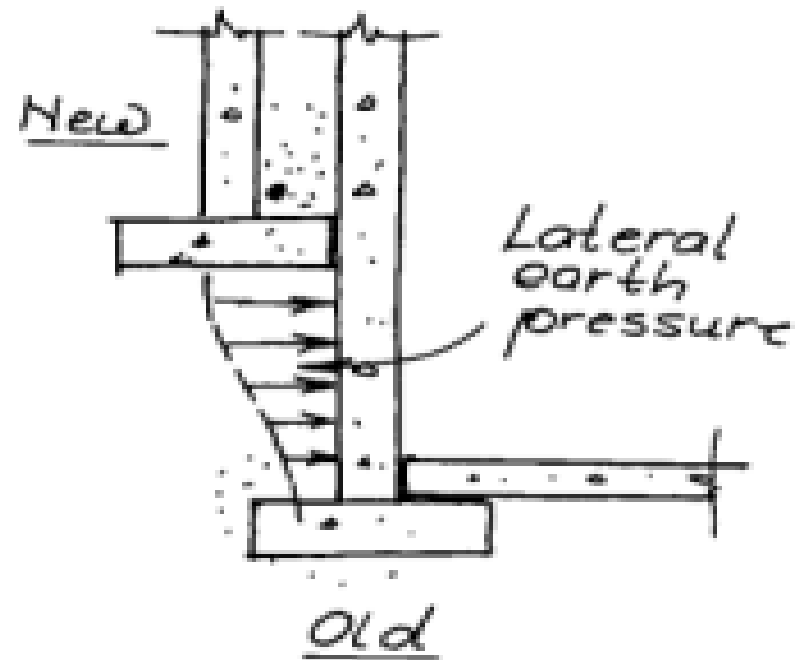

(b)

# Changes in Excavation Conditions

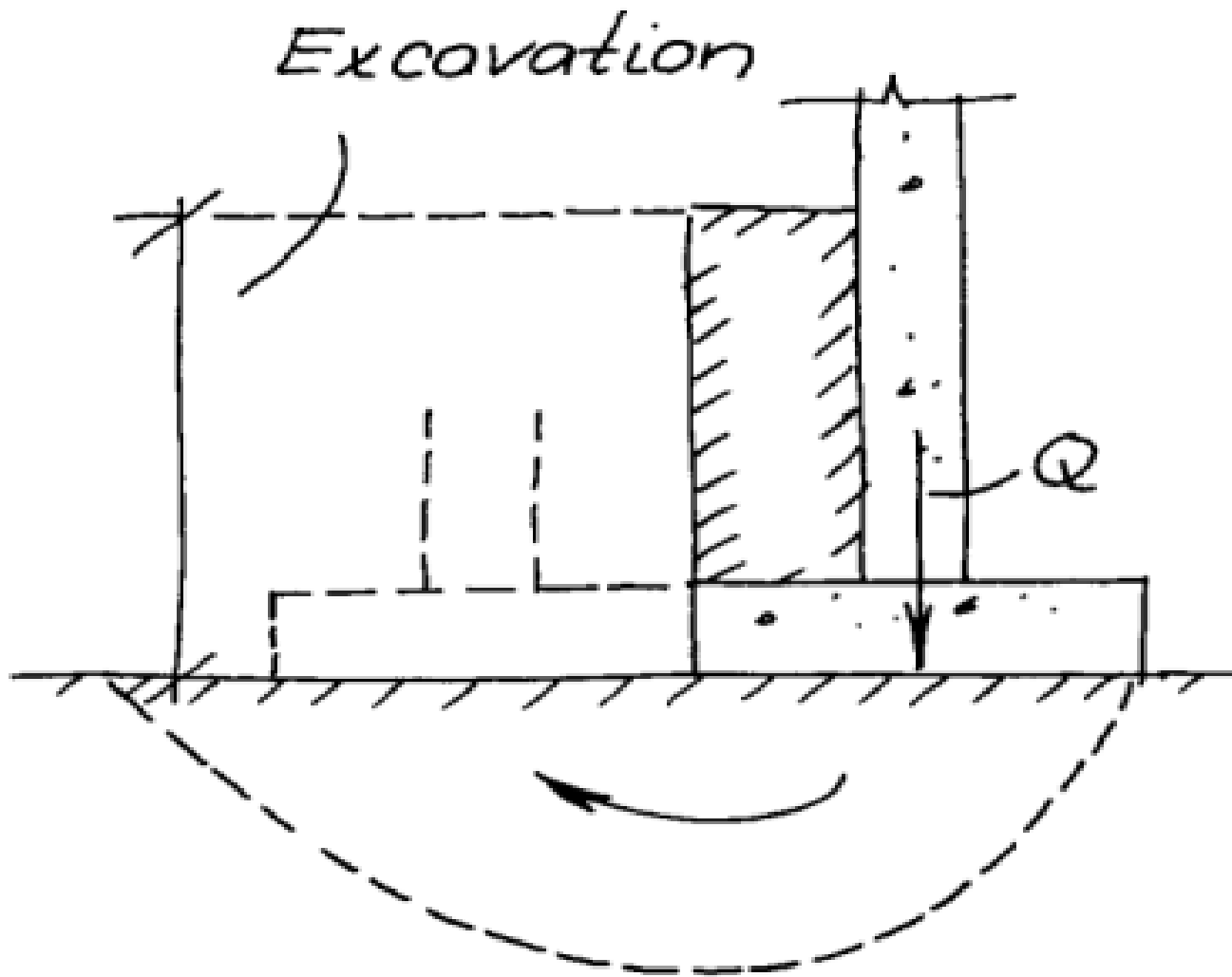

# Deterioration of Structures

- Environmental attack is an important consideration in design of foundations
  - Corrosion
  - Sulphate attack on concrete
  - Marine borers on timber structures
  - Fire on timber structures
- Although environmental attack is more common with marine structures, but is also present on non-marine structures as well

# Environments for Foundation Deterioration

Marine Environments

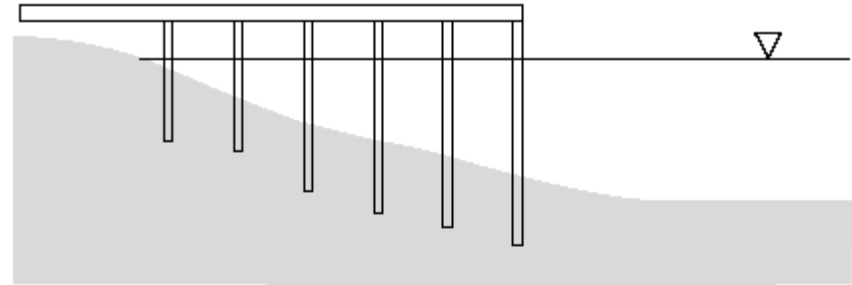

(a)

Land Environments

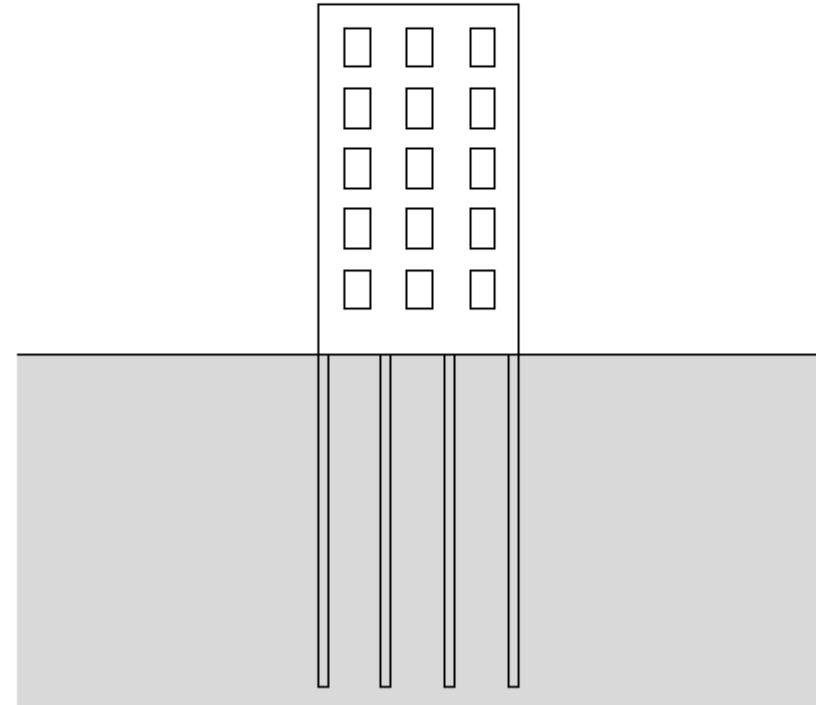

(b)

# Solutions for Metal Corrosion

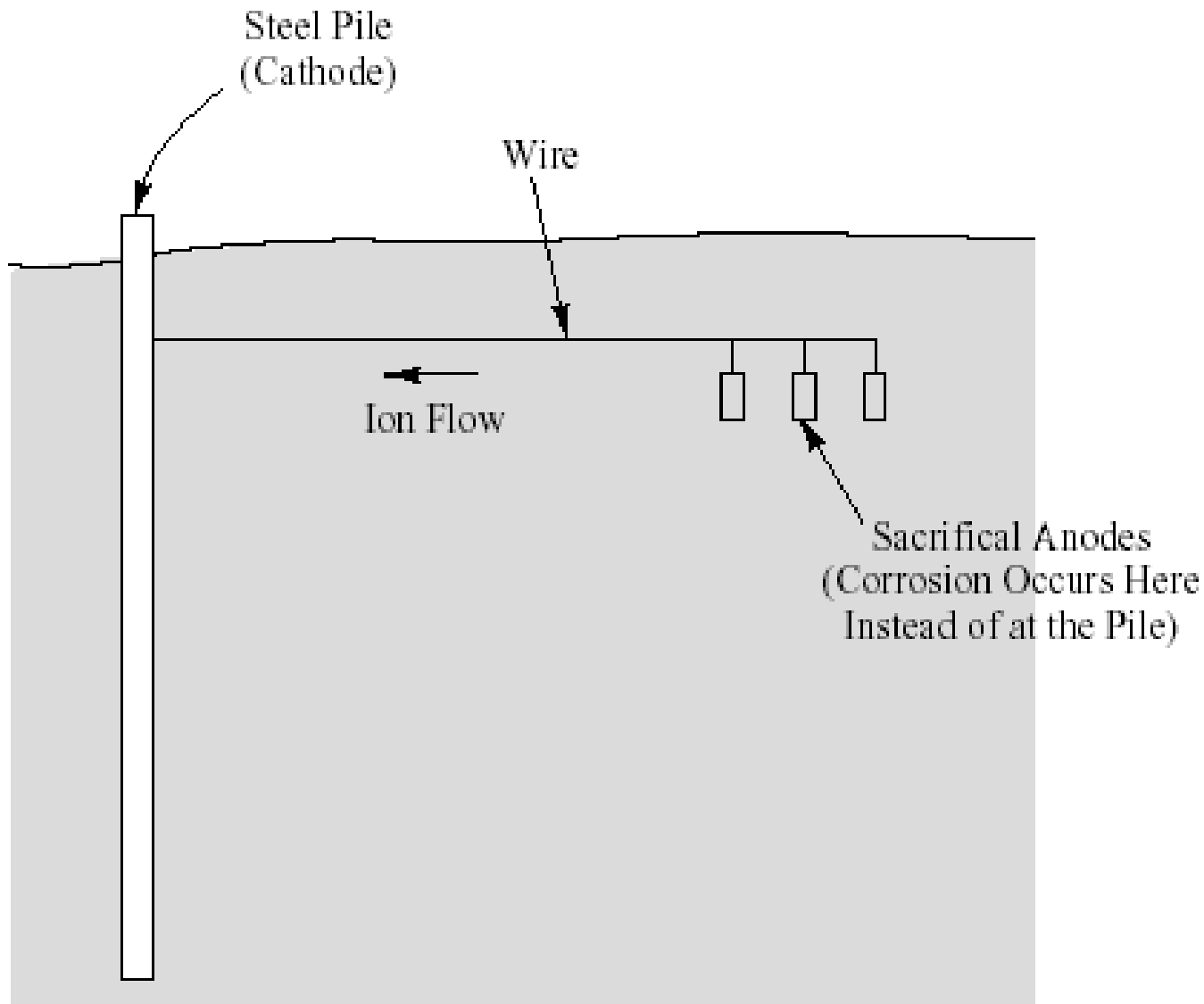

# Constructibility Requirements

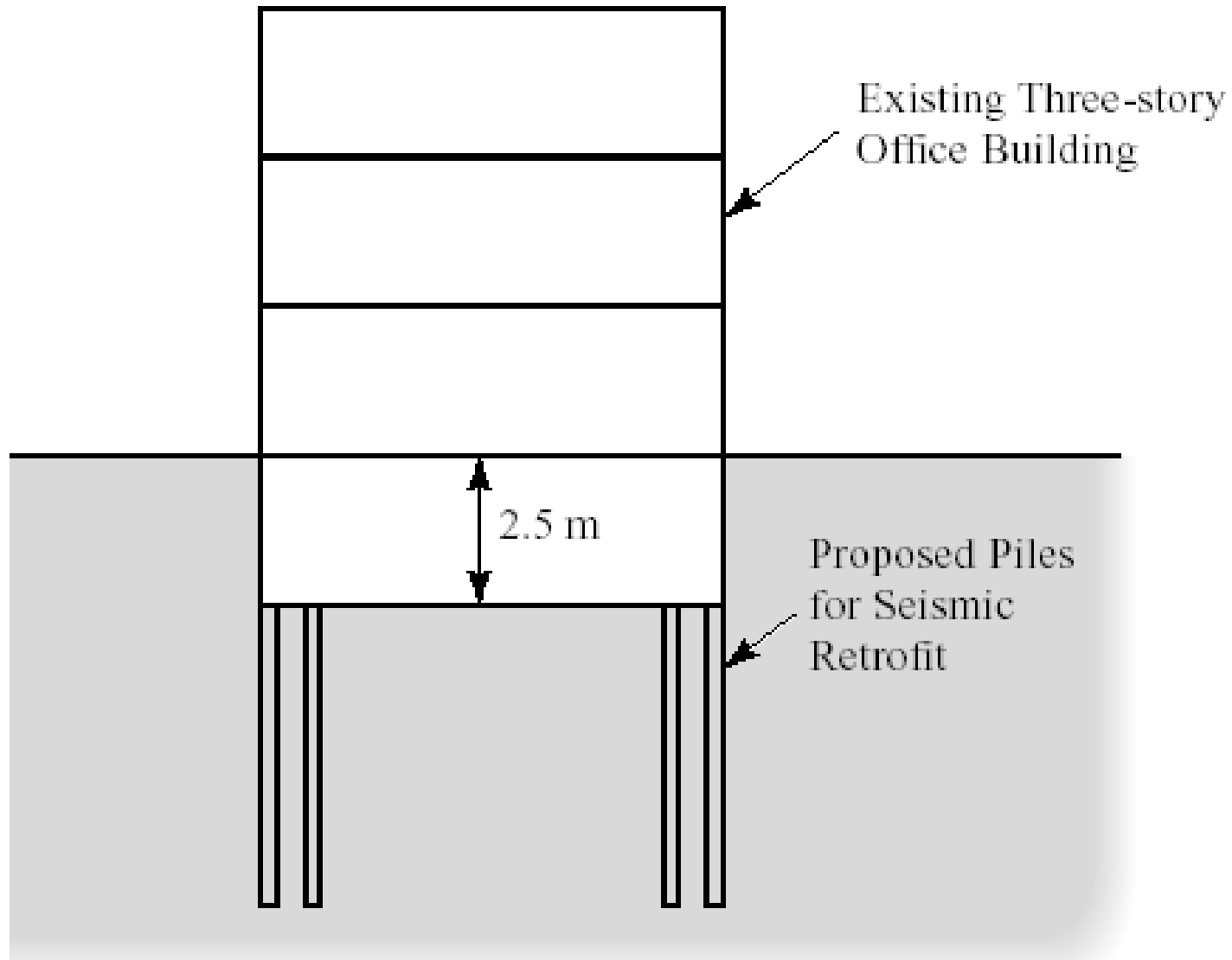

# Economic Requirements

- Foundation design tends to be more conservative than structural design because the unknowns are not as well quantified
- Consequences of catastrophic foundation failure are much greater, as the entire structure fails with the foundation
- Reduction in weight may not be beneficial in foundation design, depending upon the circumstance

**Questions?**

