

this document downloaded from

vulcanhammer.net

Since 1997, your complete online resource for information geotechnical engineering and deep foundations:

The Wave Equation Page for Piling

Online books on all aspects of soil mechanics, foundations and marine construction

Free general engineering and geotechnical software

And much more...

Terms and Conditions of Use:

All of the information, data and computer software ("information") presented on this web site is for general information only. While every effort will be made to insure its accuracy, this information should not be used or relied on for any specific application without independent, competent professional examination and verification of its accuracy, suitability and applicability by a licensed professional. Anyone making use of this information does so at his or her own risk and assumes any and all liability resulting from such use. The entire risk as to quality or usability of the information contained within is with the reader. In no event will this web page or webmaster be held liable, nor does this web page or its webmaster provide insurance against liability, for any damages including lost profits, lost savings or any other incidental or consequential damages arising from the use or inability to use the information contained within.

This site is not an official site of Prentice-Hall, Pile Buck, the University of Tennessee at Chattanooga, or Vulcan Foundation Equipment. All references to sources of software, equipment, parts, service or repairs do not constitute an endorsement.

**Visit our
companion site**

<http://www.vulcanhammer.org>

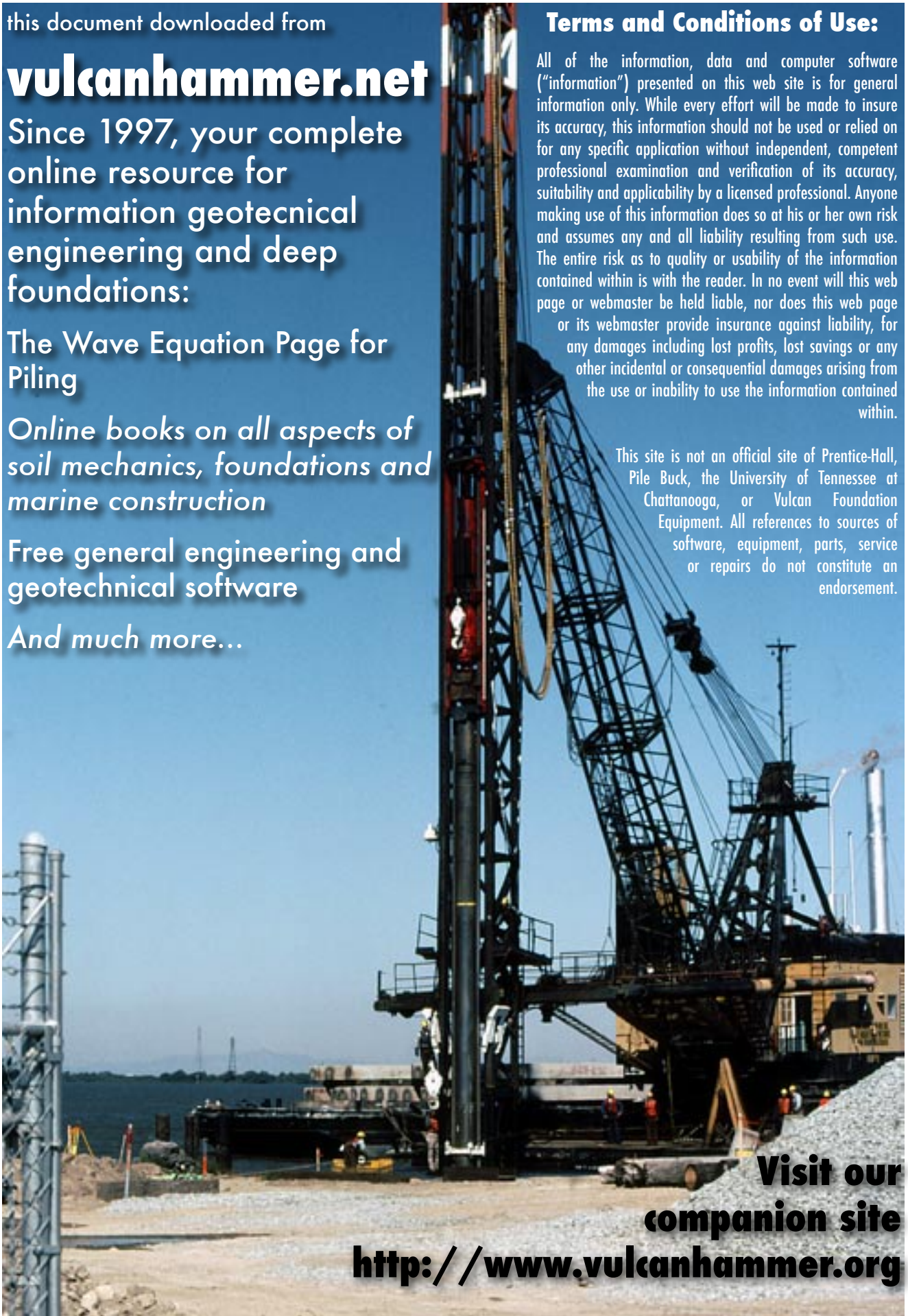

University of Tennessee at Chattanooga
ENCE 461

Foundation Analysis and Design

Fall 2009



Don C. Warrington, P.E., Instructor

Catalog Description

- Fundamentals of soil mechanics as applied to the analysis and design of foundation systems
- Subsurface investigations
- Design of shallow and deep foundations
- Retaining structures and lateral earth pressures.

Textbook and Reference Books

- Textbook
 - Coduto, D.P. *Foundation Design: Principles and Practices*, 2nd ed. Upper Saddle River, NJ: Prentice Hall, 2001.
- Reference Book
 - NAVFAC DM 7.02, *Foundations and Earth Structures*. Naval Facilities Engineering Command, Alexandria, Virginia, 1986.
 - Available from vulcanhammer.net website

Line Drawing Credit

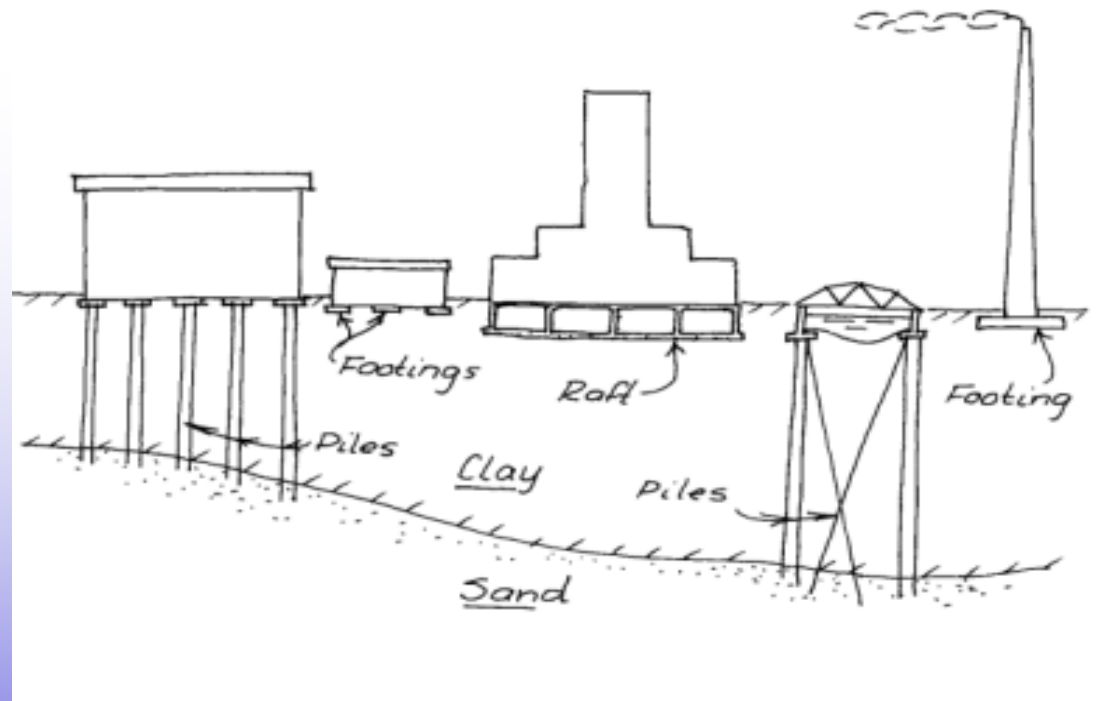

Dr. Bengt Broms
Foundation Design

Evaluation

- Homework: 25%
 - Due date for homework assignments will be announced when assignment is given.
 - Homework turned in after due date will have 10% deducted from grade for each class period late.
 - Homework turned in after last class session will be given a grade of zero.
- Mid-Term Exam: 15%
- Final Exam: 19%
- Design Project: 25%
- Four (4) Unannounced Quizzes @ 4% each: 16%

Class Notebook

- You are required to keep and assemble a three-ring (or other suitable binding) notebook with the following divisions in it:
 - Homework
 - Quizzes
 - Tests
 - Reports
 - Class Notes (Optional)
- You will turn this notebook in at the final exam. It will be inspected and returned to you.

Appearance of Work

- All homework and tests must be on engineering paper.
- Homework and tests must conform to format given in syllabus. Failure to do so will result in reduced credit.
- Each time you use an equation, write down what it is: don't just put a bunch of numbers on the page and expect anyone to know what you did. This too will result in reduced credit.

Honor System

- You are encouraged to work homework with someone but your turned in work must be your own work.
- You are studying now so that you may enter and practice the engineering profession later. The engineering profession is highly regarded by the public because those who practice it do so with ethical and social consciousness. The same is expected of students in this course. Any direct copying of homework, tests or exams will be considered a violation of the honour code and a course grade of “F” will be given.

Types of Foundations

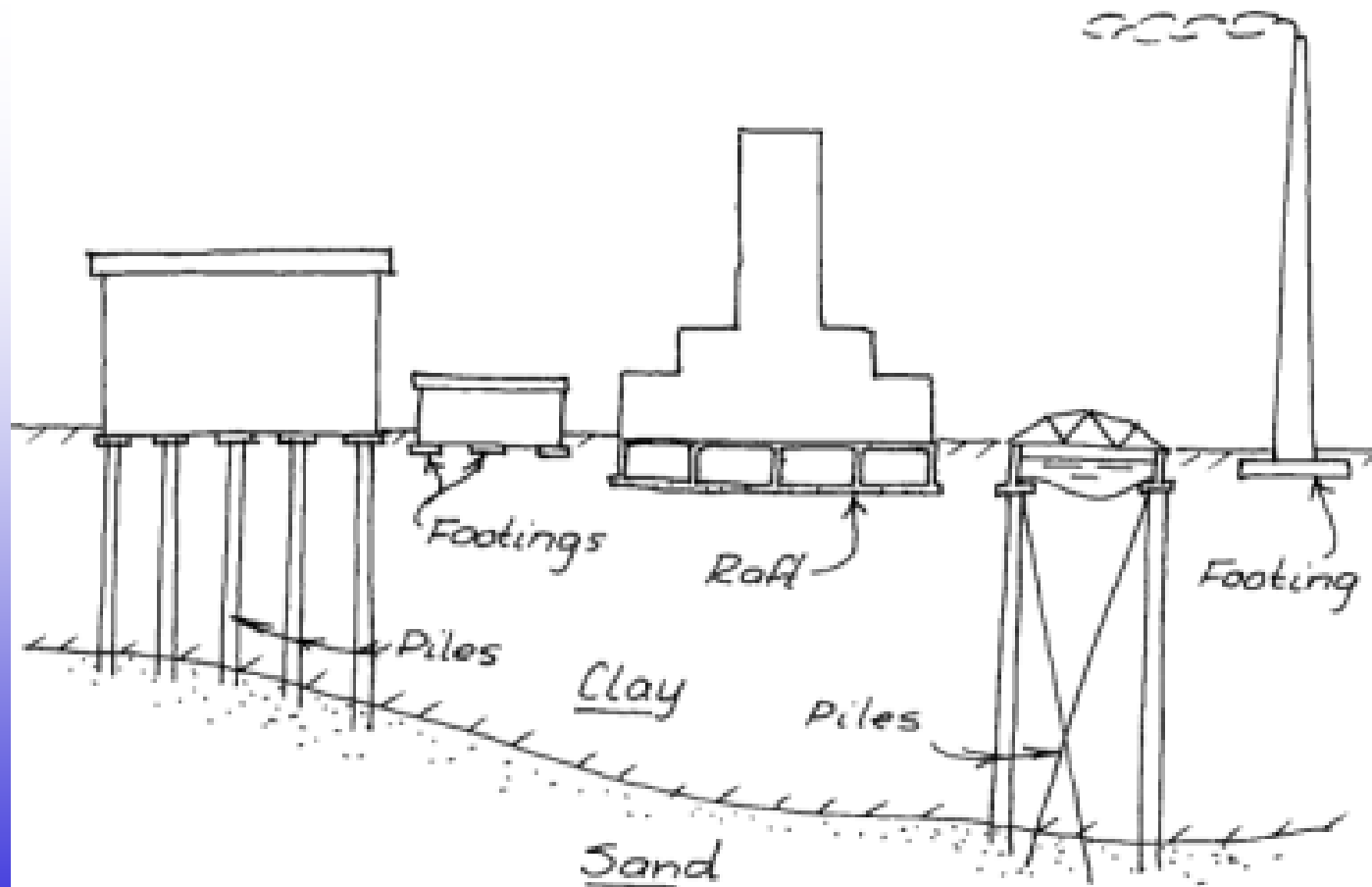

Types of Foundations

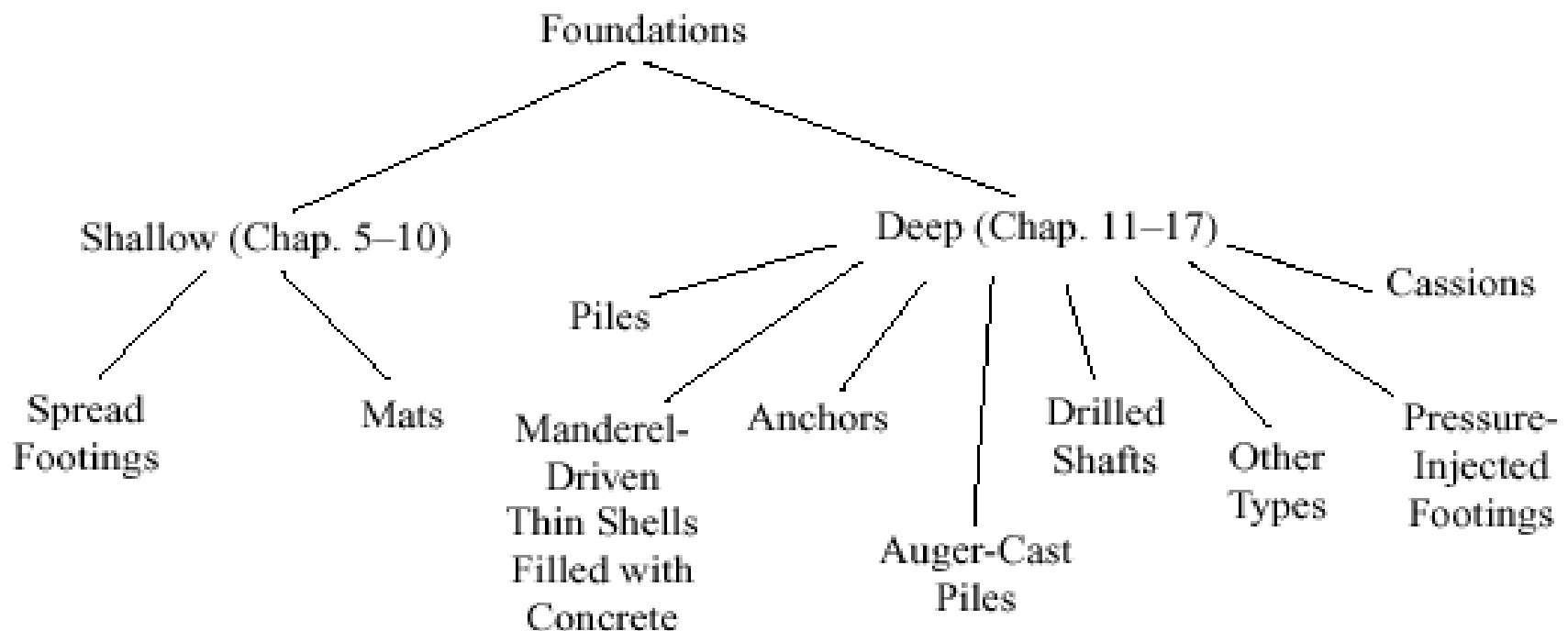

Types of Foundations

- Shallow Foundations
 - Spread Footings
 - Mat or Raft Foundations
 - Suitable when soil has sufficient bearing capacity at or near grade, either naturally or by soil improvement
- Deep Foundations
 - Driven Piles
 - Drilled Shafts
 - Caissons
 - Required when shallow foundations will not carry the load

Types of Foundations

- Floating Foundations
 - Used when displaced soil and groundwater weight is sufficiently large to « float » the foundation on the surface
- Lateral Earth Retaining Structures
 - Gravity Walls
 - Gabion Walls
 - Sheet Piling Walls
 - Reinforced Earth Walls
 - Slopes (supported and unsupported)
 - Used for necessary elevation changes of structure(s)

Methods of Foundation Analysis

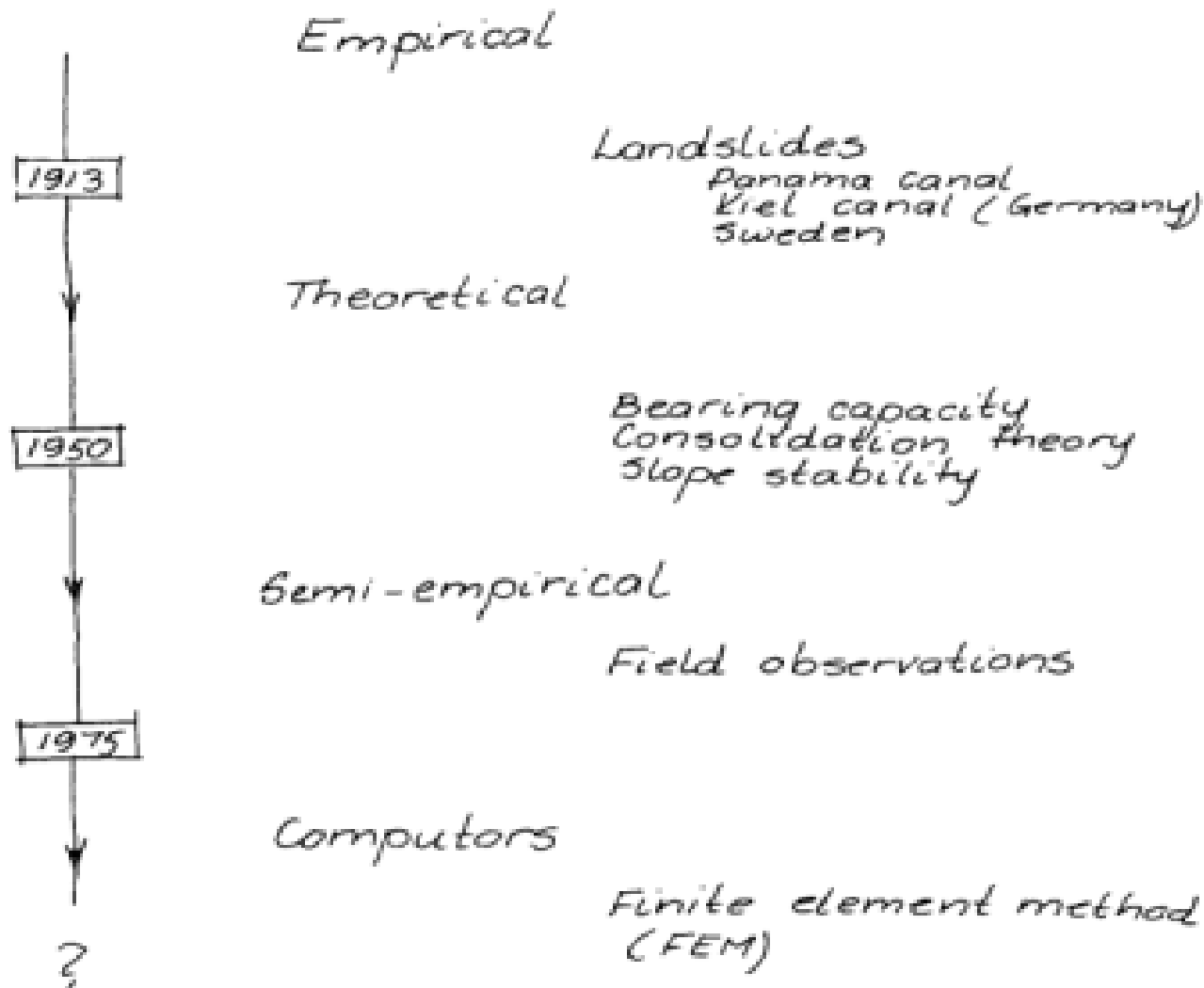

Sources of Information for Solution of Foundation Problems

- Experience obtained by trial and error in the past; this developed into the empirical or "rule of thumb" procedures for today. The weakness of this approach is not recognizing differences in the engineering properties of soils. What works well at one location may not succeed with the same type of soil at another location.
- Information on the properties of soils; generally obtained by field explorations and laboratory tests. Subsequent, theoretical analysis results will only be as good as the soils data used as input.
- Scientific principles from various fields of engineering and science; used to explain or predict the behavior of soils under various conditions.

Considerations for Foundation Design

1. Economical
2. Adequate safety (F_s)
(Bearing capacity, sliding, overturning etc)
3. Small settlements
(Total and differential settlements)
4. Small seasonal changes
(drying, frost, heave)
5. Construction problems (stability of excavation, bottom heave, ground water problems, vibrations, noise etc)
6. Environmental effects
(E.g. permanent lowering of the ground water level)

What to Analyze in Foundation Design

- Components of Foundation Design
 - Structural capacity of foundation materials and structures
 - Bearing or friction resistance of soils
- Modes of Failure
 - Bearing Failure (usually catastrophic)
 - Settlement Failure (usually not catastrophic but damage to supported structure results)

Selecting a Foundation Type

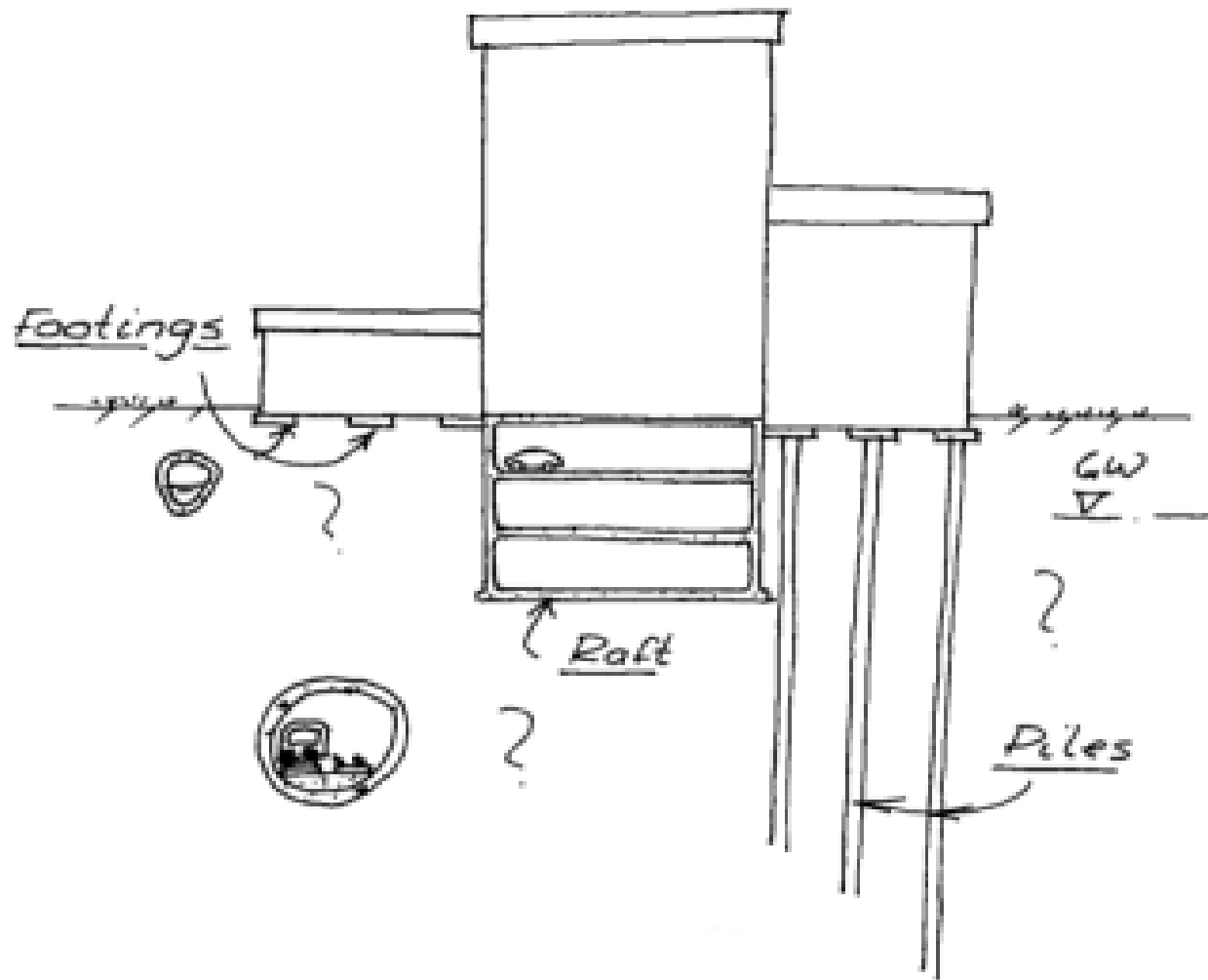

Typical Soil Profile

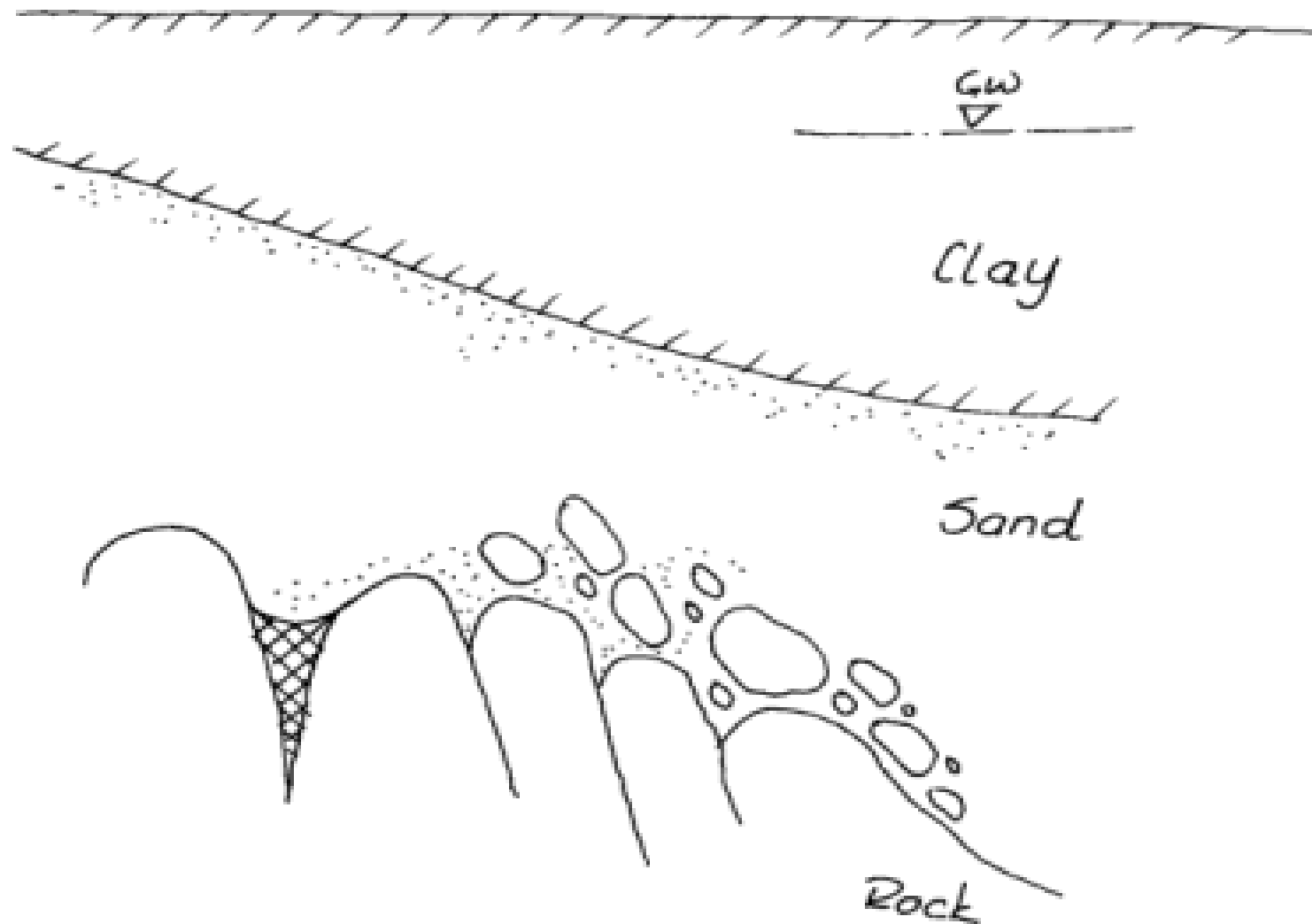

Methods of Analysis of Soil Properties

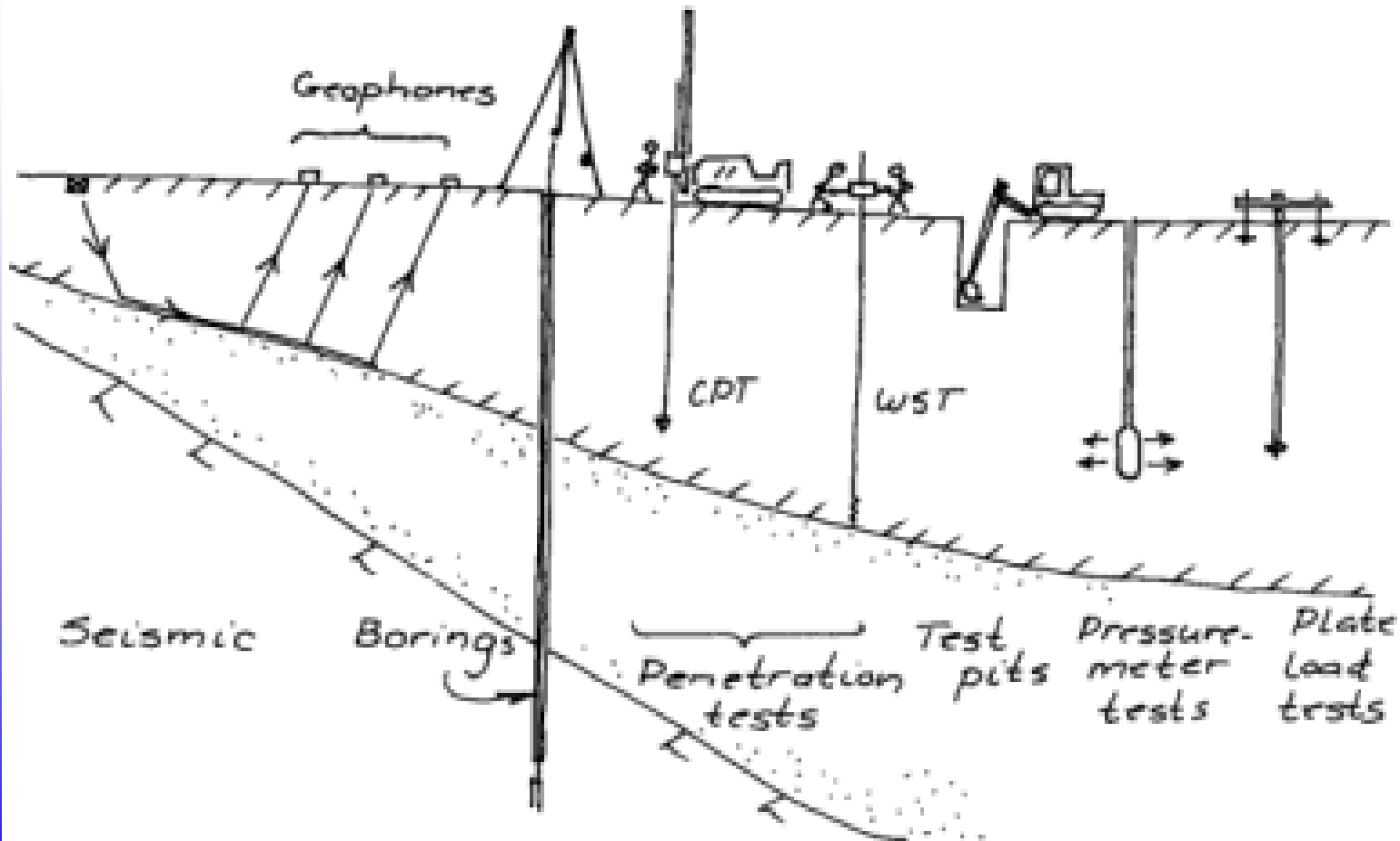

Consideration of Neighboring Underground Structures

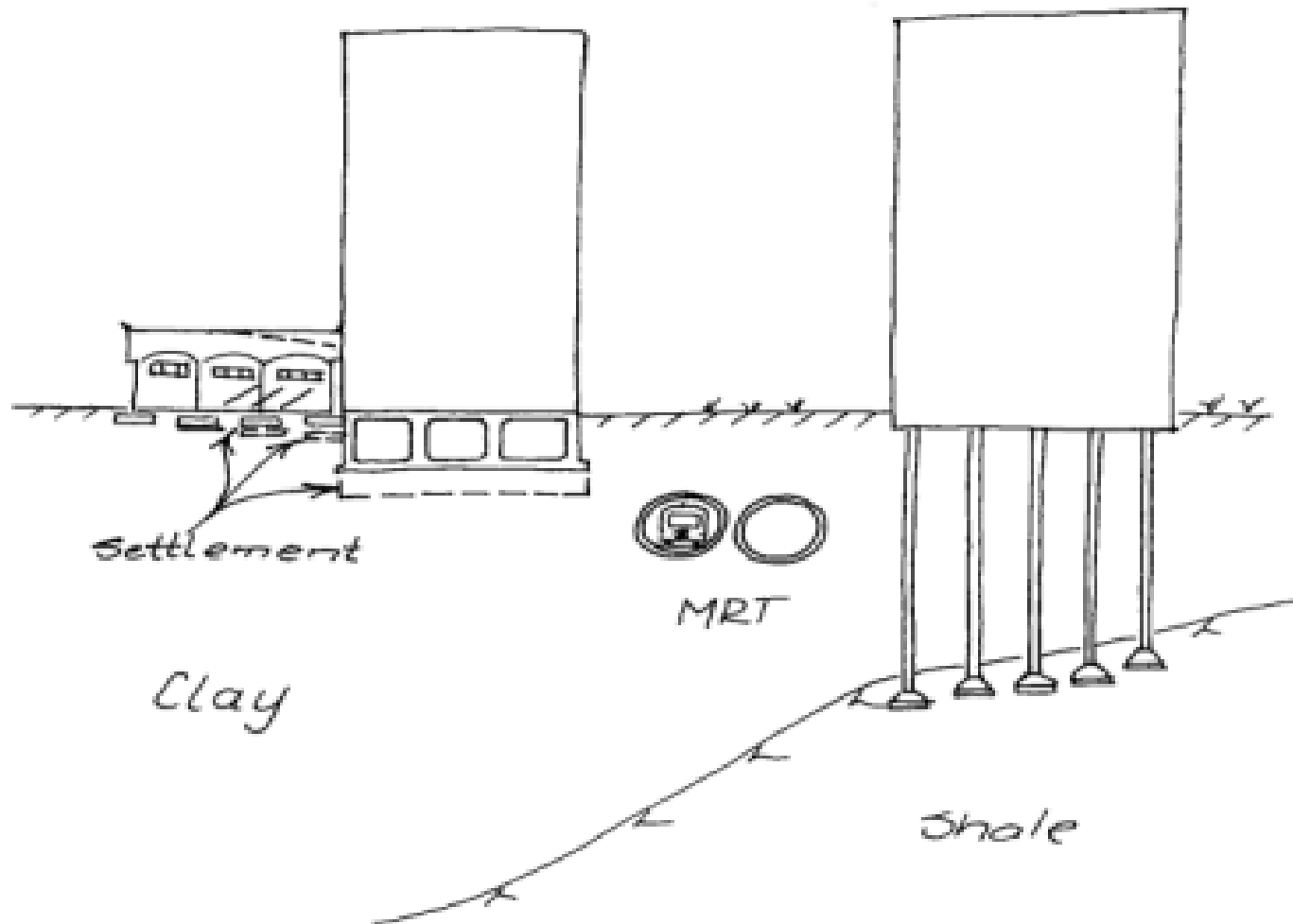

Foundations Around Slopes

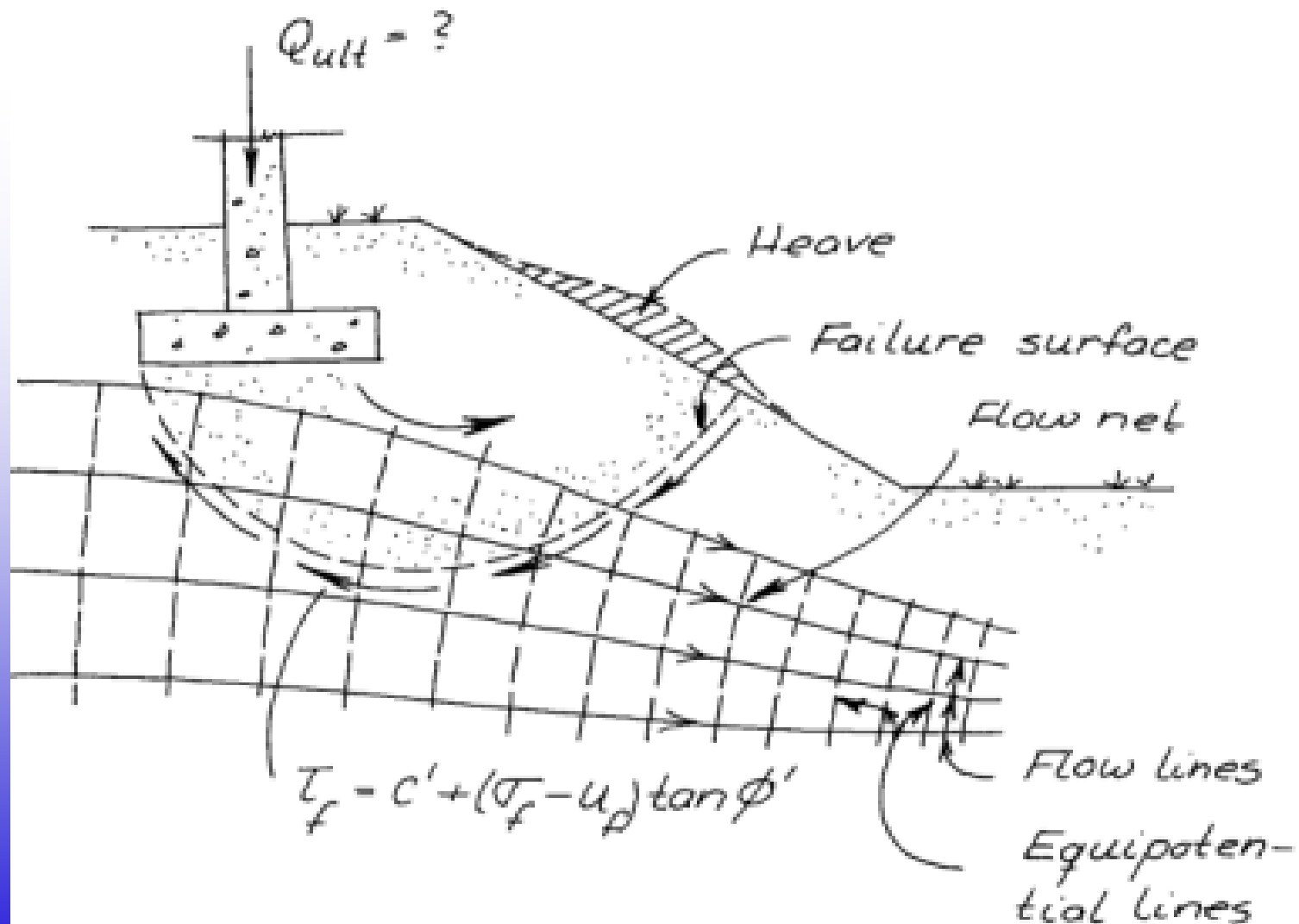

Failure by Soil Failure or Excessive Settlement?

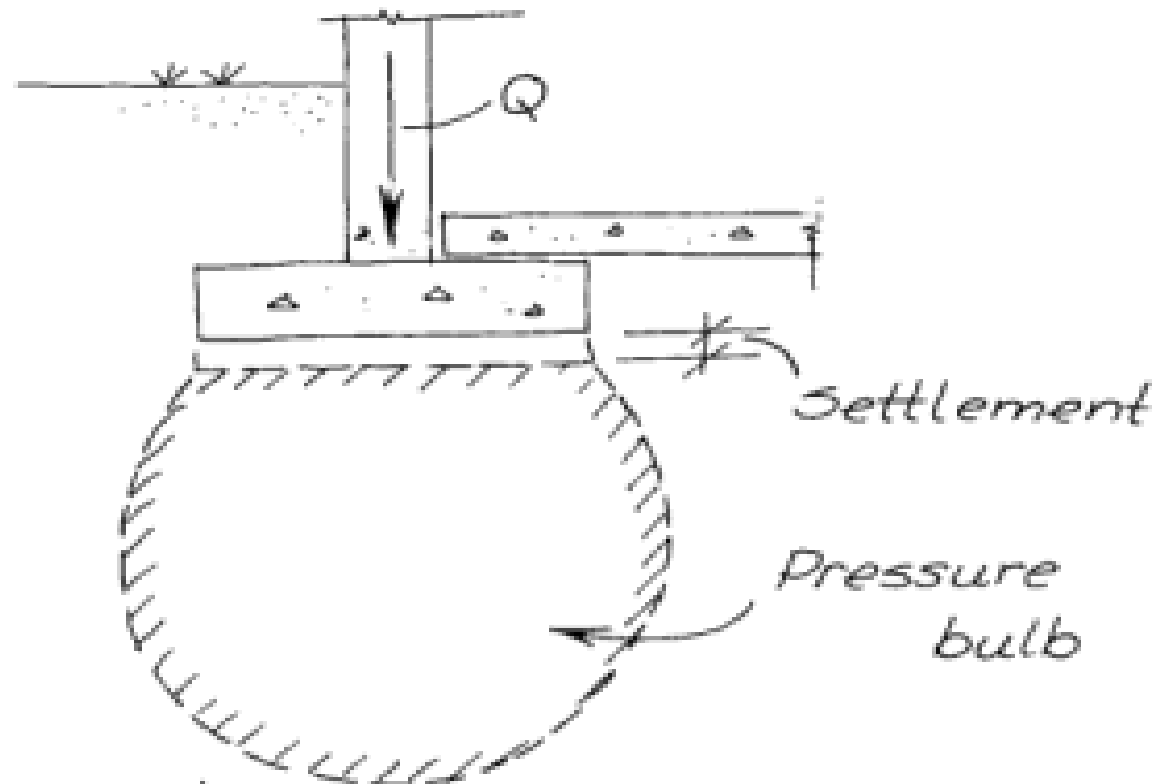

Settlement

- (a) stress increase, $\Delta\sigma$
- (b) Compressibility, C_c , E_{soil} , ν_{soil}

Differential Settlement

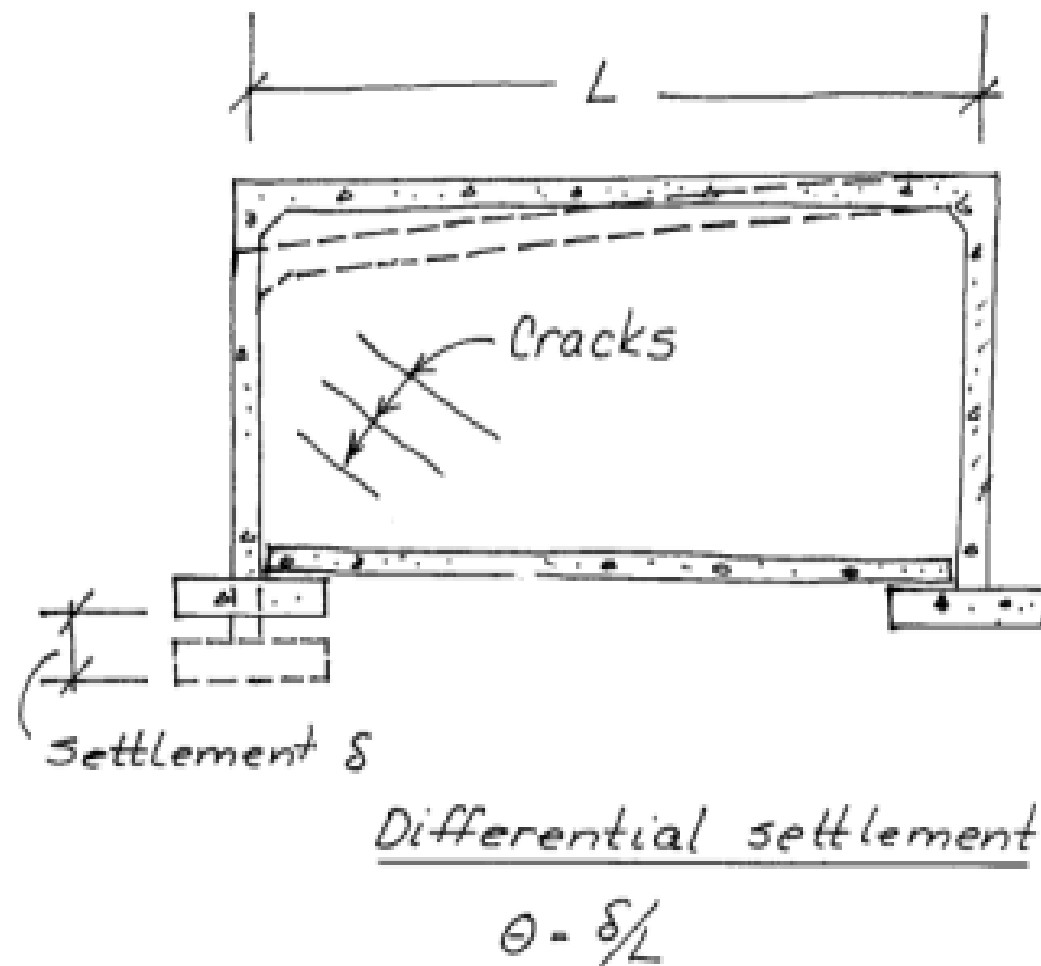

Groundwater Effects

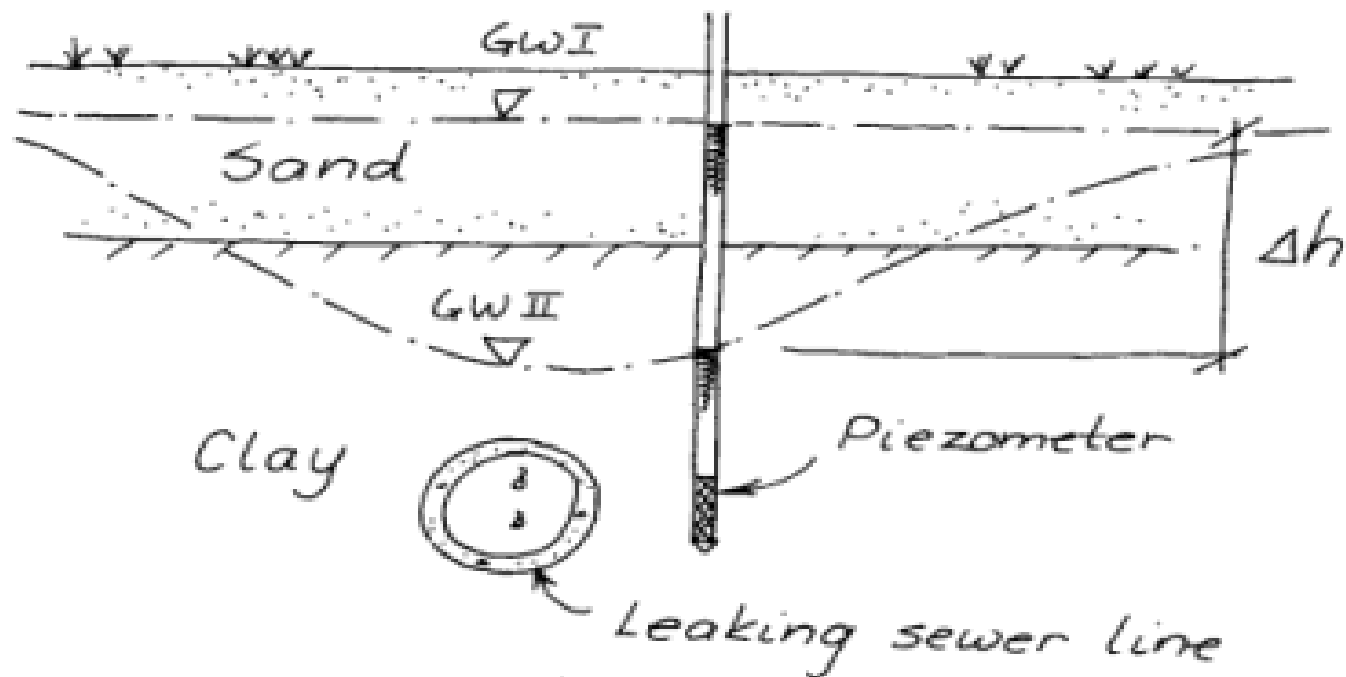

$$\Delta u = \Delta h f_w$$

$\Delta \sigma'$ \swarrow

\nwarrow 10 kN/m^3

At $\Delta h = 1.0 \text{ m}$

$$\Delta u = 1 \cdot 10 = 10 \text{ kPa.}$$

Mat Foundations: Elasticity of Soil and Foundation

Mat foundation.

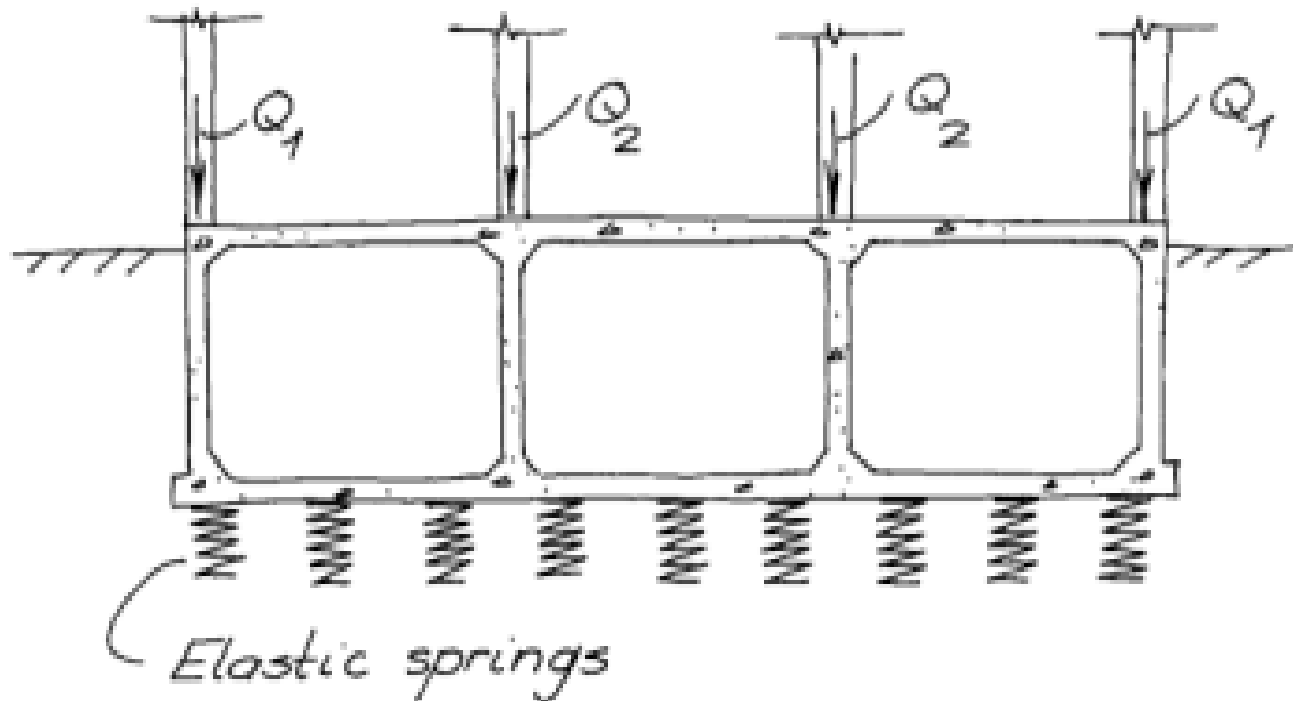

Deep Foundations

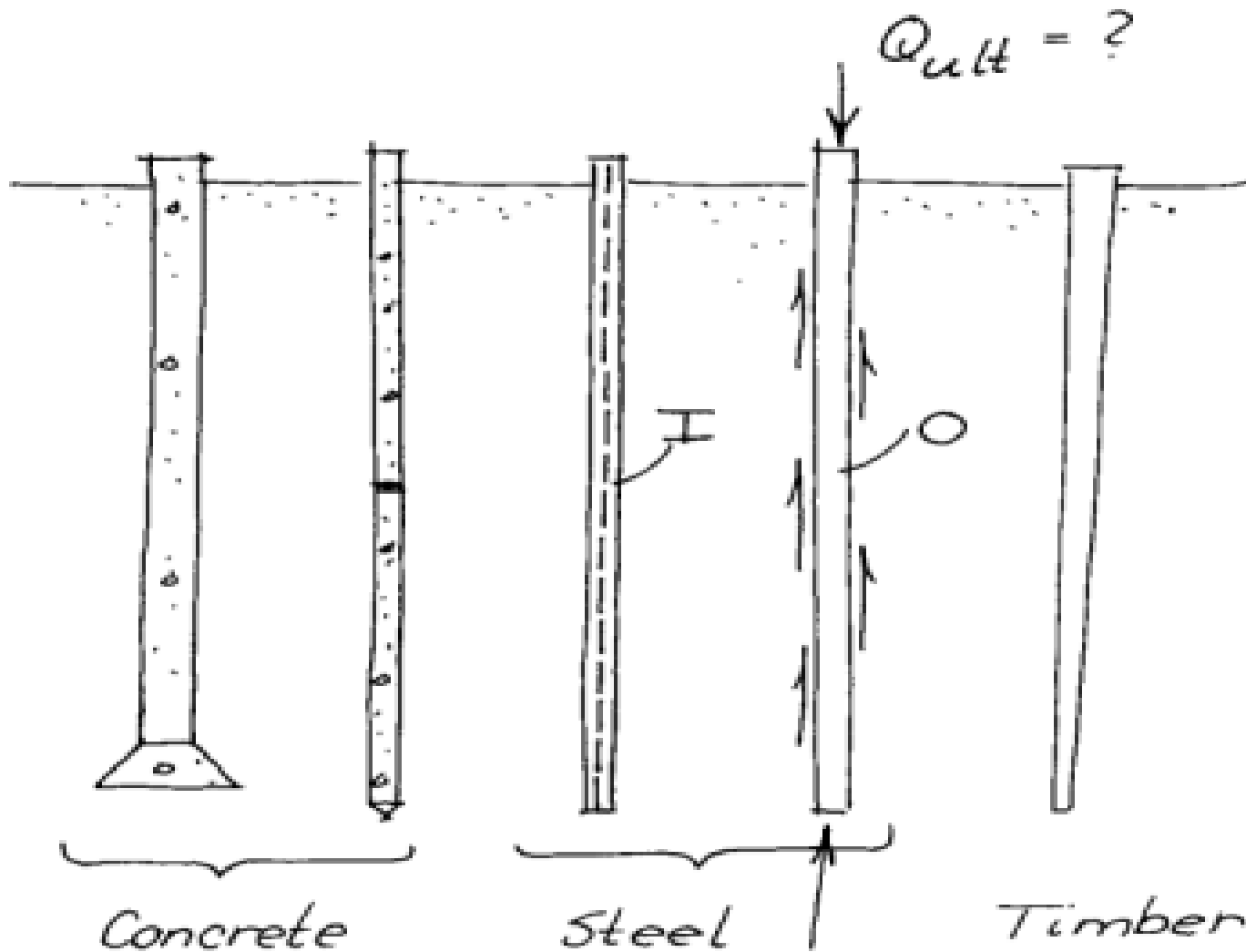

Loading Conditions for Deep Foundations

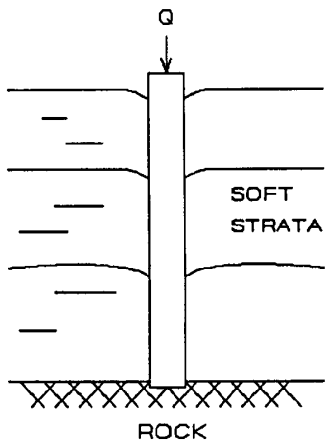

a. ENDBEARING PILE

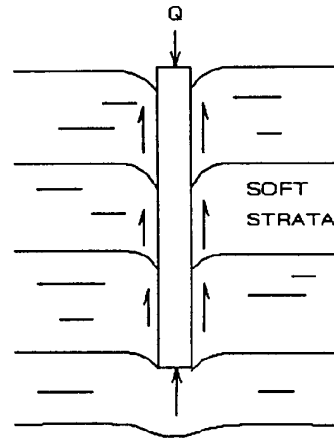

b. FRICTION PILE

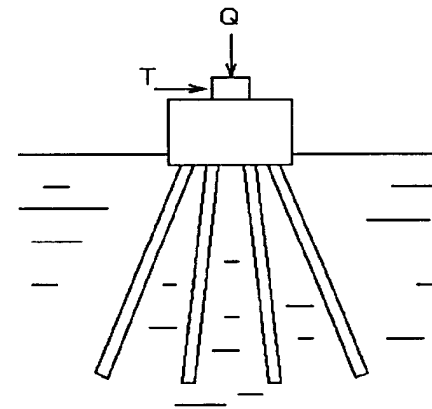

e. BATTERED GROUP

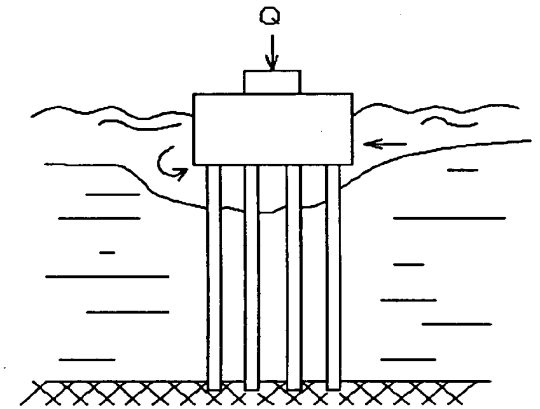

f. LOAD TRANSFER BELOW SCOUR DEPTH

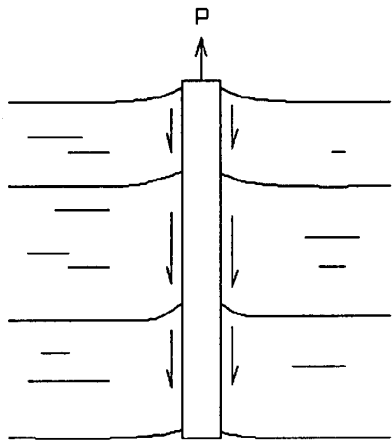

c. TENSION PILE

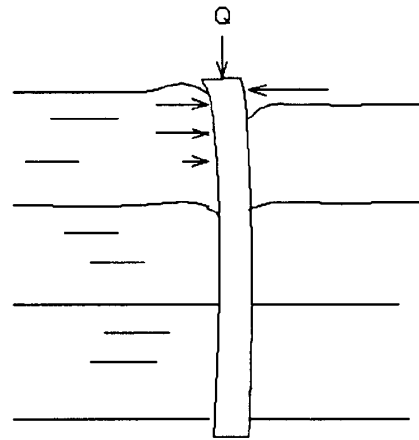

d. RESISTANCE TO BENDING

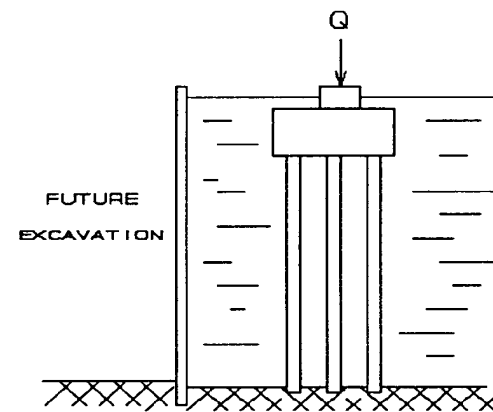

g. SUPPORT FOR FUTURE EXCAVATION

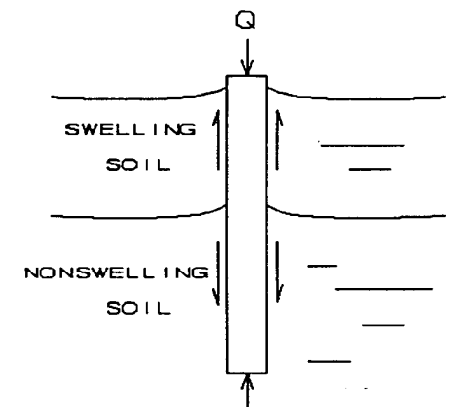

h. PILE ANCHORED IN NONSWELLING SOIL

Driven Pile Foundations



Load Transmission in Deep Foundations

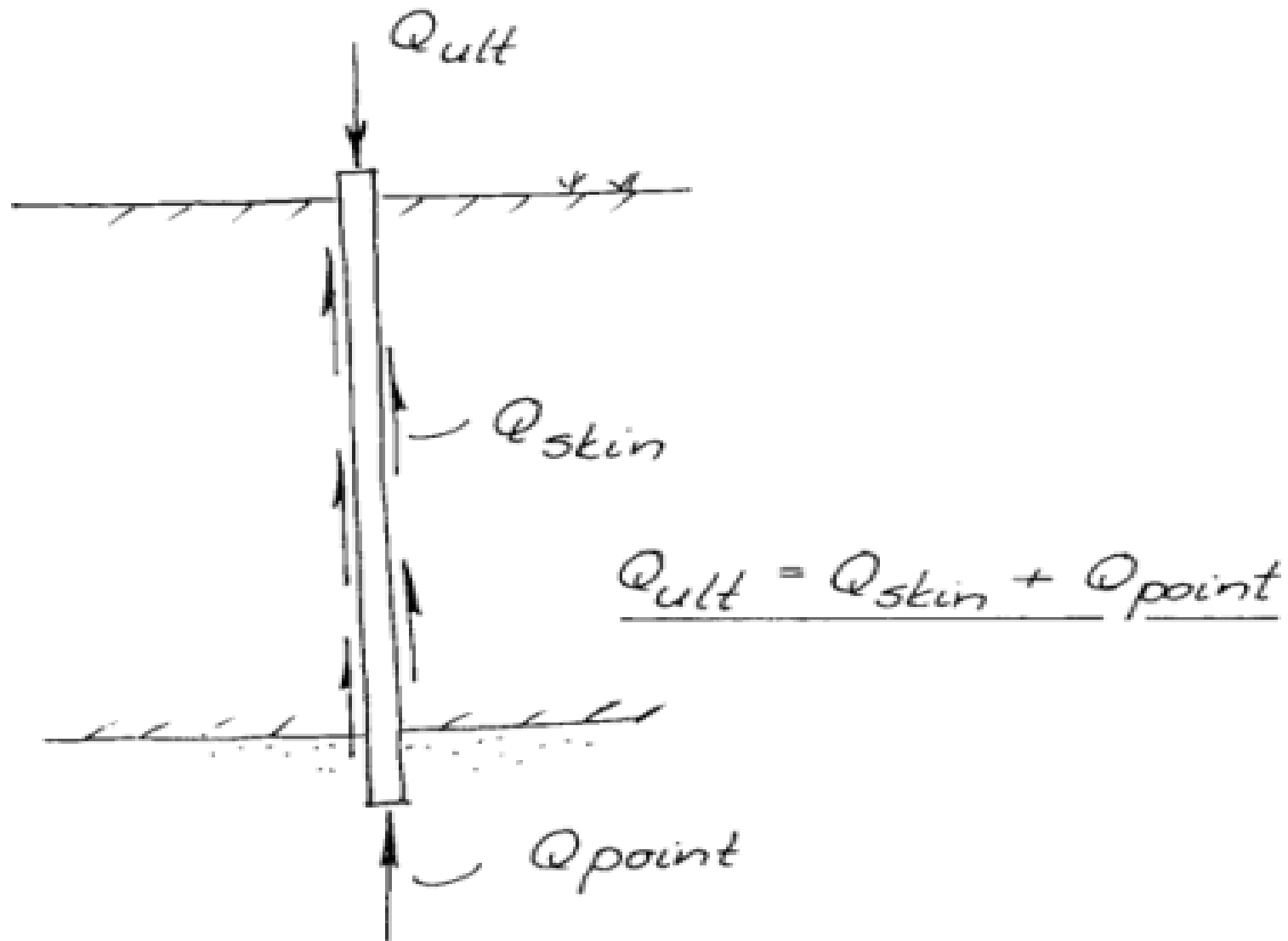

Uplift Loading



Lateral Loading



Retaining Walls

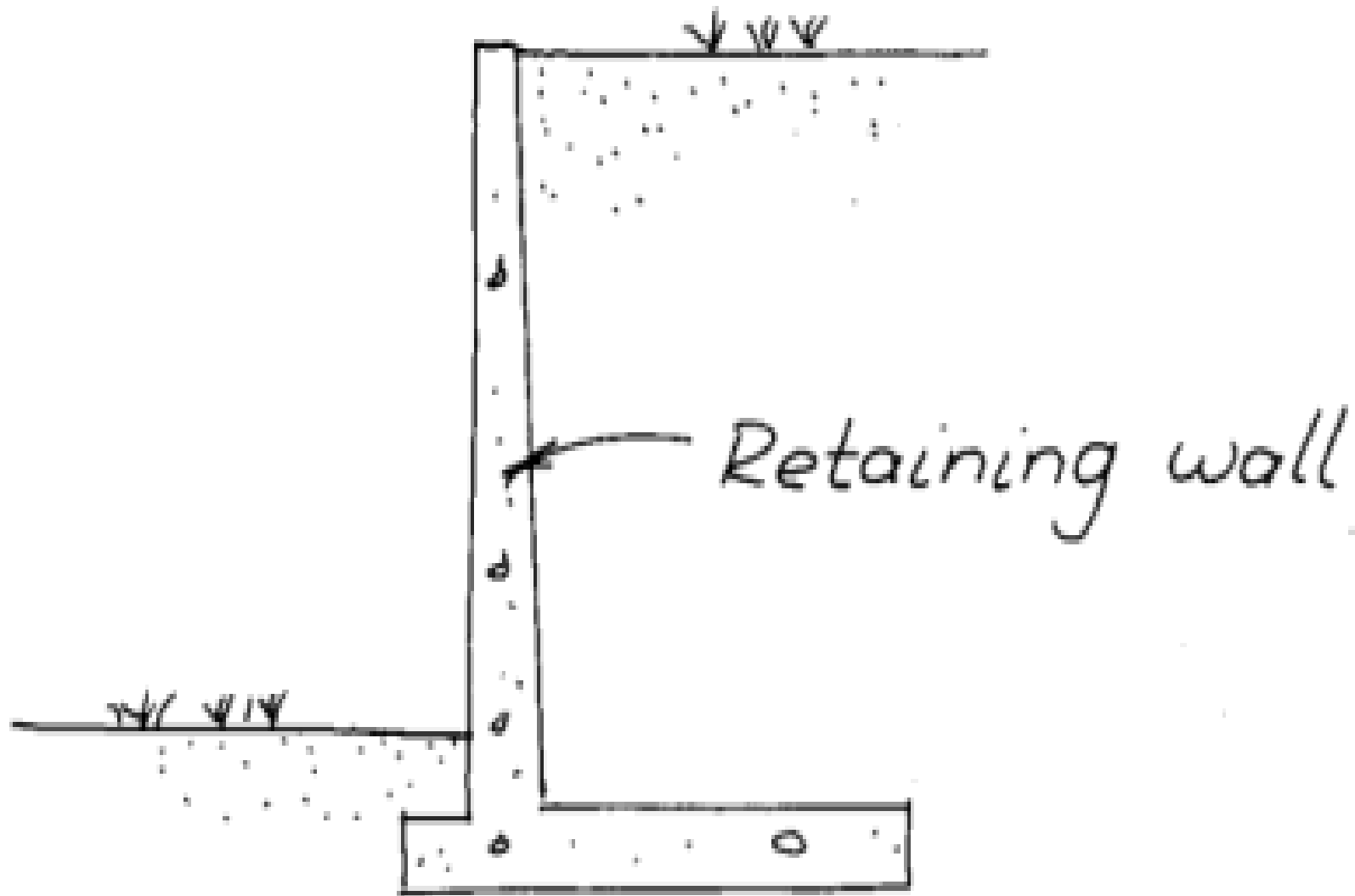

Anchored Sheet Piling Wall

Anchored sheet pile walls

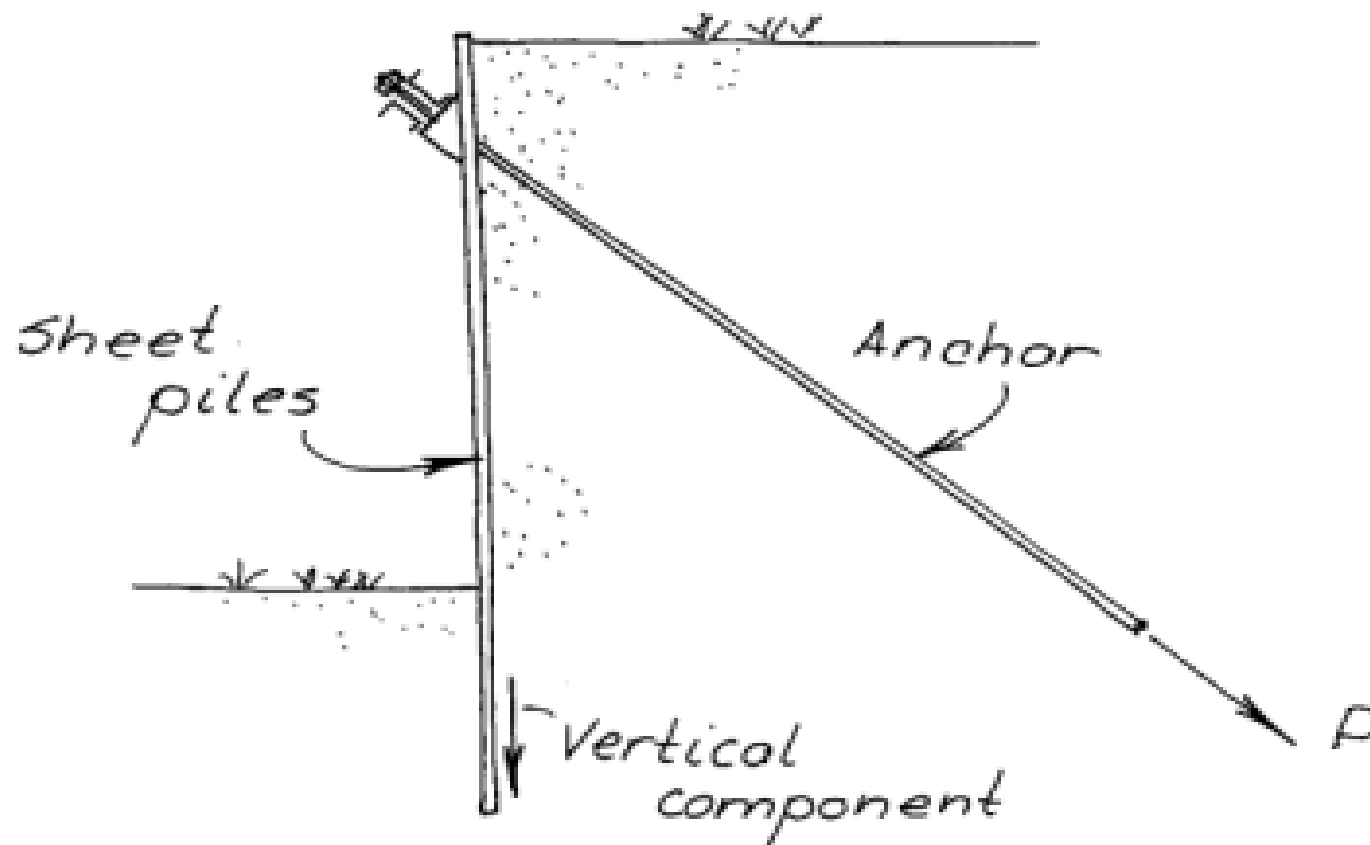

Sheet Piling Walls



Braced Cuts

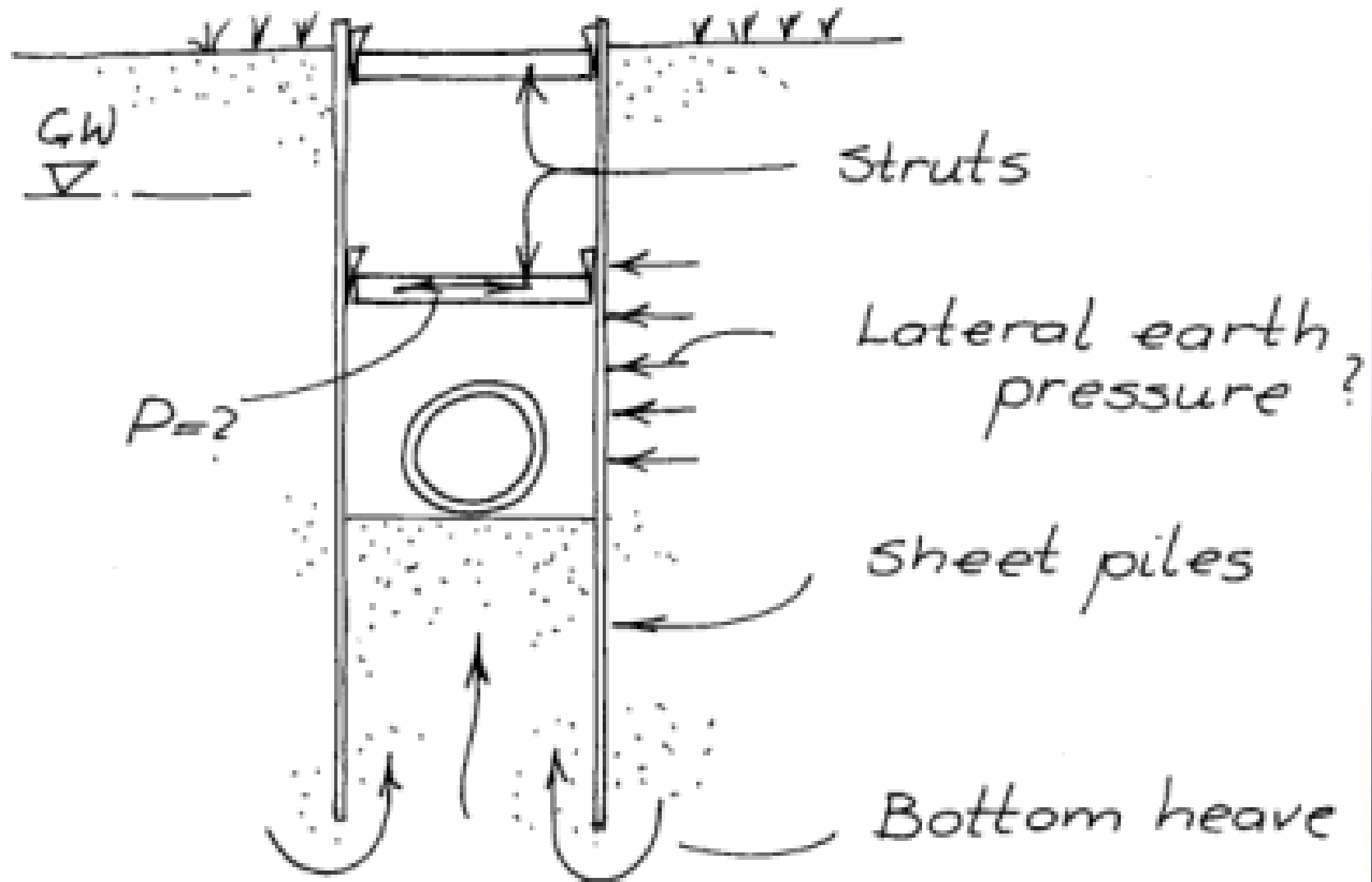

Other Methods of Reinforcement

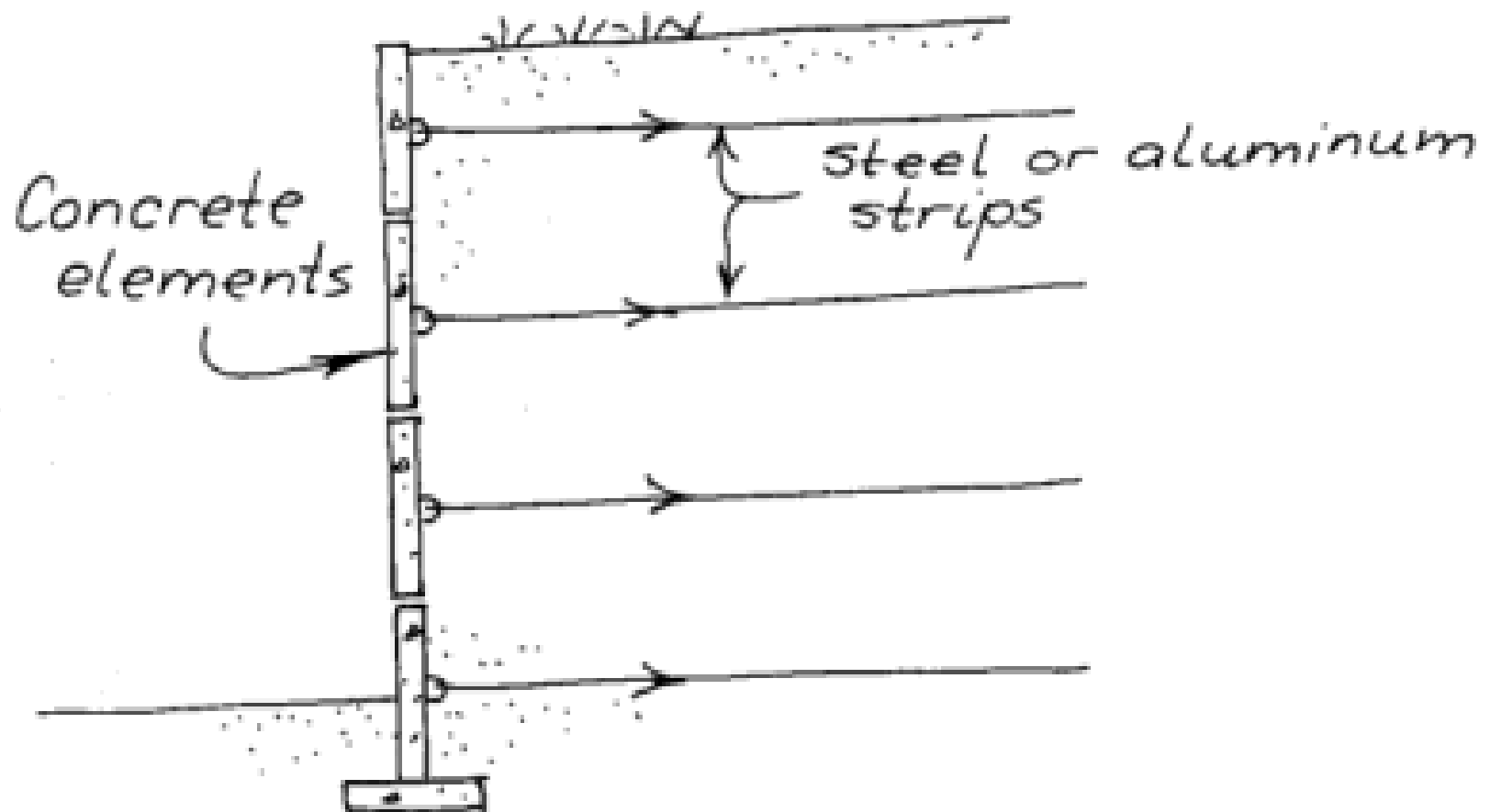

Combination of Foundation Types

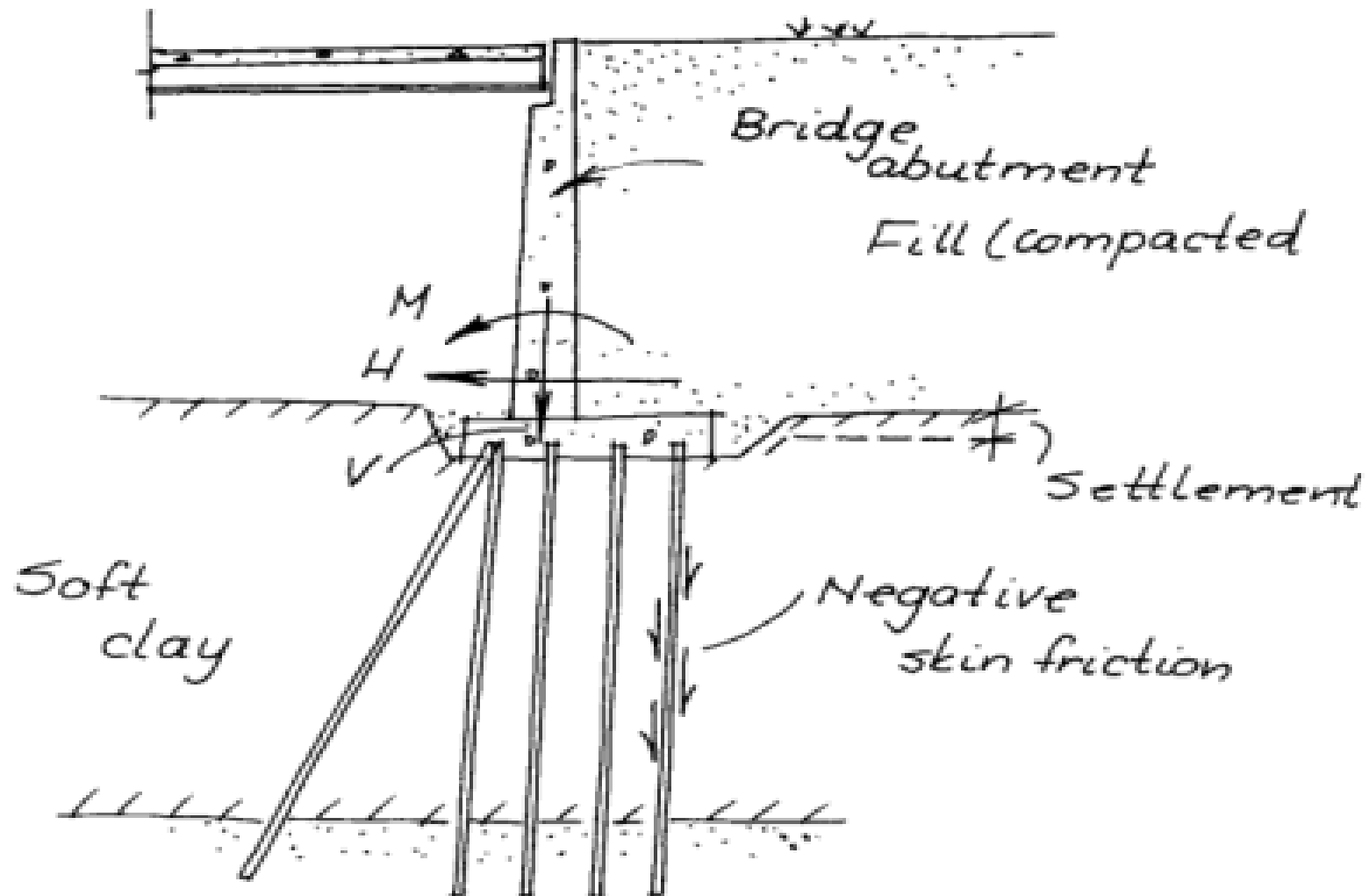

The Problem of Constructibility

« The successful transfer of design objectives into construction is accomplished by consideration of construction operations during the design phase. In recent years the amount of coordination between design and construction has steadily decreased; primarily due to graduate engineers who specialize in design and who are never exposed to construction operations. In past years, engineers either began their careers in construction and advanced into design, or were assigned the design and construction responsibilities for projects. Present lack of coordination stemming from inexperience with field operations can result in a technically superior set of construction plans and specifications which cannot be built. Rational construction control is vital to assure a safe, cost-effective foundation and to avoid unnecessary court of claims actions.»

(Chaney & Chassie, *Soils and Foundations Workshop Manual*, FHWA HI-88-009)

Homework Set 1

- Textbook Reading:
 - Coduto, Chs. 1, 2, 5 & 6
- Problems
 - 2.1, 2.2, 2.6, 2.12, 5.2, 5.5, 5.7, 6.2, 6.6
 - Due Date: 2 September 2009

Questions

