

this document downloaded from

vulcanhammer.net

Since 1997, your complete online resource for information geotechnical engineering and deep foundations:

The Wave Equation Page for Piling

Online books on all aspects of soil mechanics, foundations and marine construction

Free general engineering and geotechnical software

And much more...

Terms and Conditions of Use:

All of the information, data and computer software ("information") presented on this web site is for general information only. While every effort will be made to insure its accuracy, this information should not be used or relied on for any specific application without independent, competent professional examination and verification of its accuracy, suitability and applicability by a licensed professional. Anyone making use of this information does so at his or her own risk and assumes any and all liability resulting from such use. The entire risk as to quality or usability of the information contained within is with the reader. In no event will this web page or webmaster be held liable, nor does this web page or its webmaster provide insurance against liability, for any damages including lost profits, lost savings or any other incidental or consequential damages arising from the use or inability to use the information contained within.

This site is not an official site of Prentice-Hall, Pile Buck, the University of Tennessee at Chattanooga, or Vulcan Foundation Equipment. All references to sources of software, equipment, parts, service or repairs do not constitute an endorsement.

**Visit our
companion site**

<http://www.vulcanhammer.org>

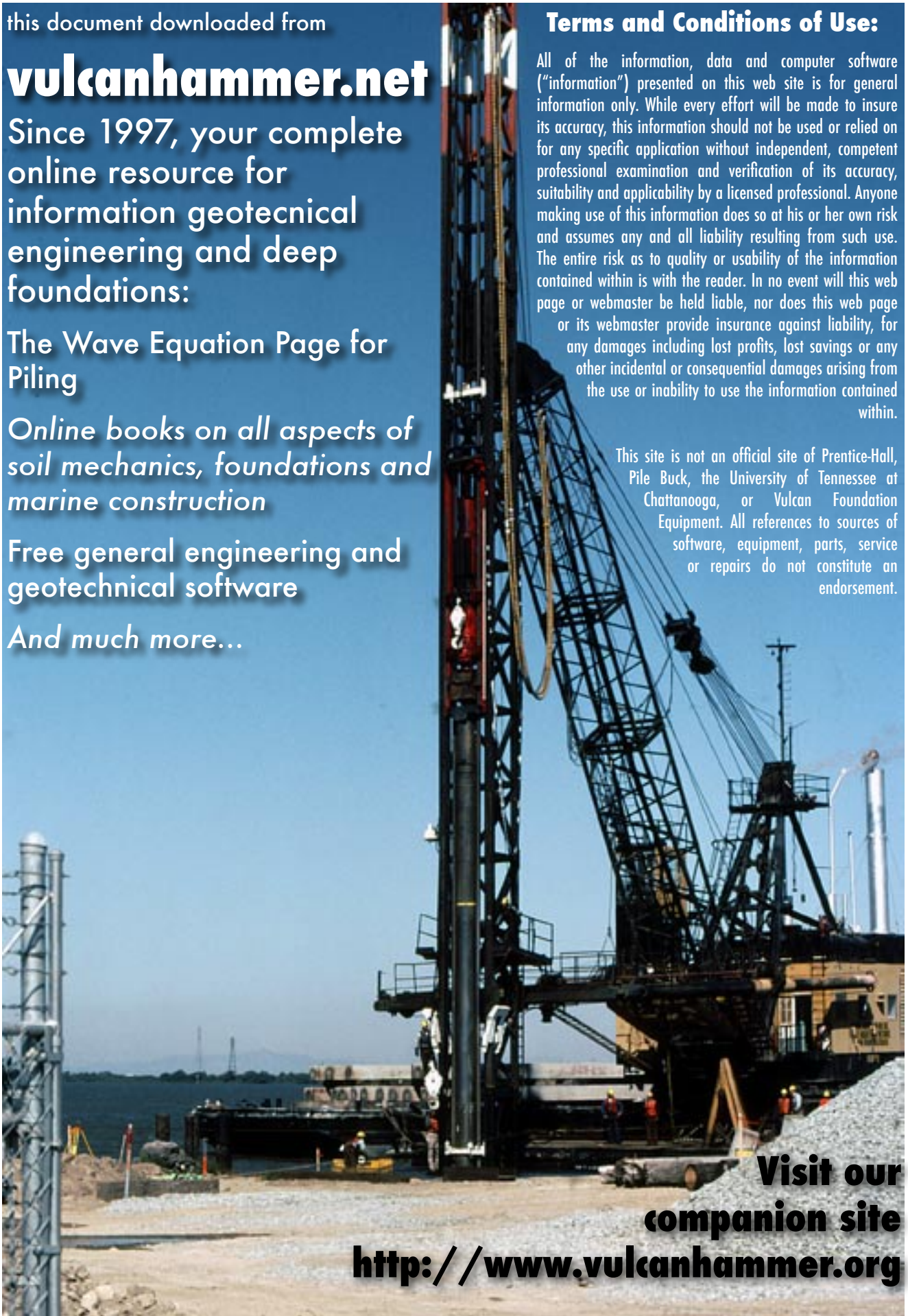

Overview of Deep Foundations

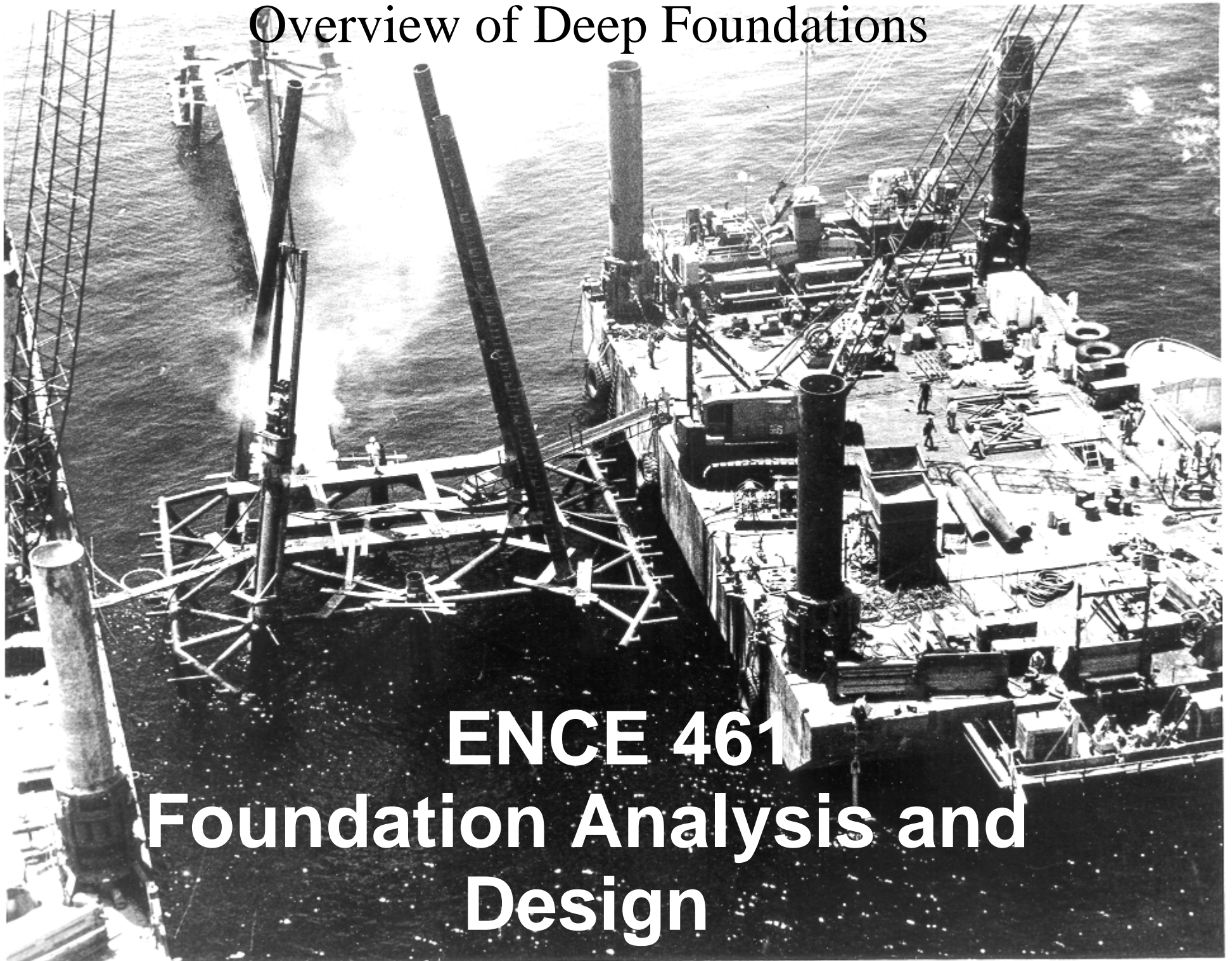

ENCE 461
Foundation Analysis and Design

Reasons for Deep Foundations

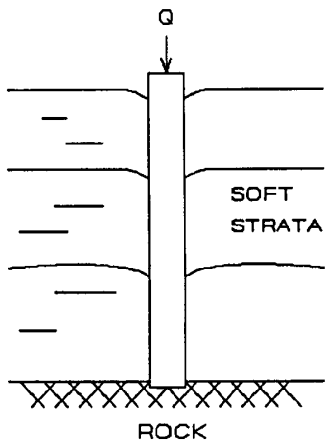

Weak Upper Soils
a. ENDBEARING PILE

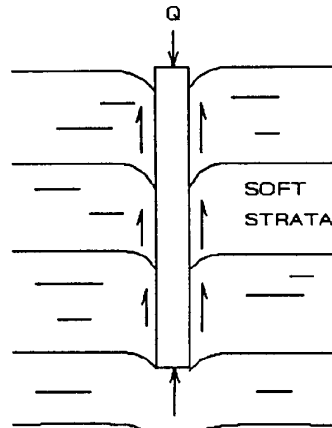

b. FRICTION PILE

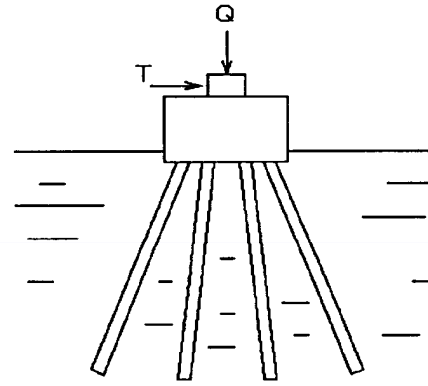

Lateral Loads
e. BATTERED GROUP

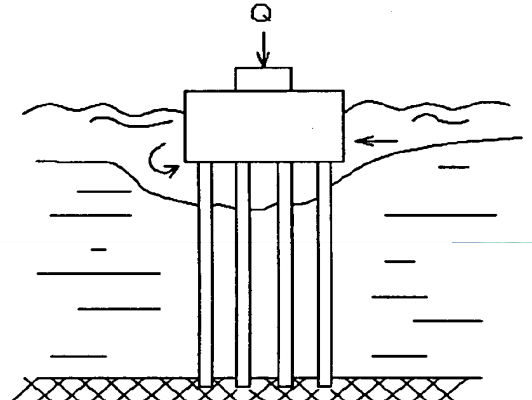

Scour or Undermining
f. LOAD TRANSFER BELOW SCOUR DEPTH

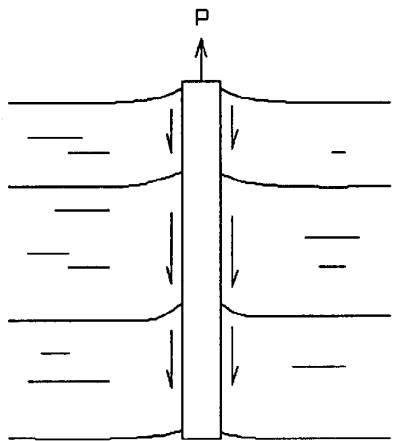

Uplift Capacity
c. TENSION PILE

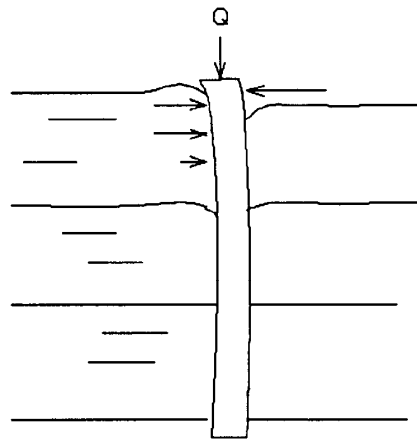

Lateral Loads
d. RESISTANCE TO BENDING

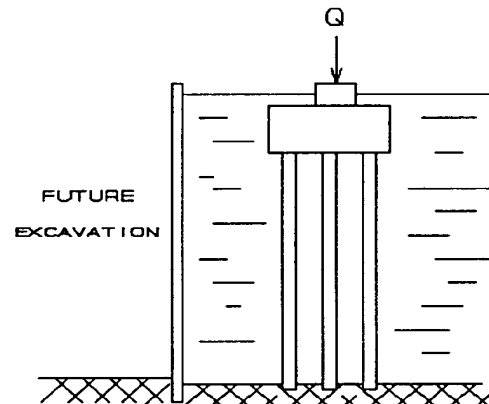

Future Excavation
g. SUPPORT FOR FUTURE EXCAVATION

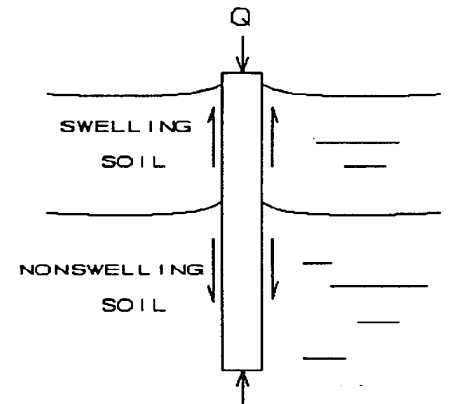

Expansive Soils
h. PILE ANCHORED IN NONSWELLING SOIL

Also: Foundations penetrating through water

Types of Deep Foundations

- Driven Piles
 - Mandrel Driven Thin-Shelled Piles Filled With Concrete (Raymond Step-Taper, etc.)
- Drilled Shafts
- Caissons
- Auger-Cast Piles
- Pressure-Injected Footings
- Anchors

Parts of Deep Foundations

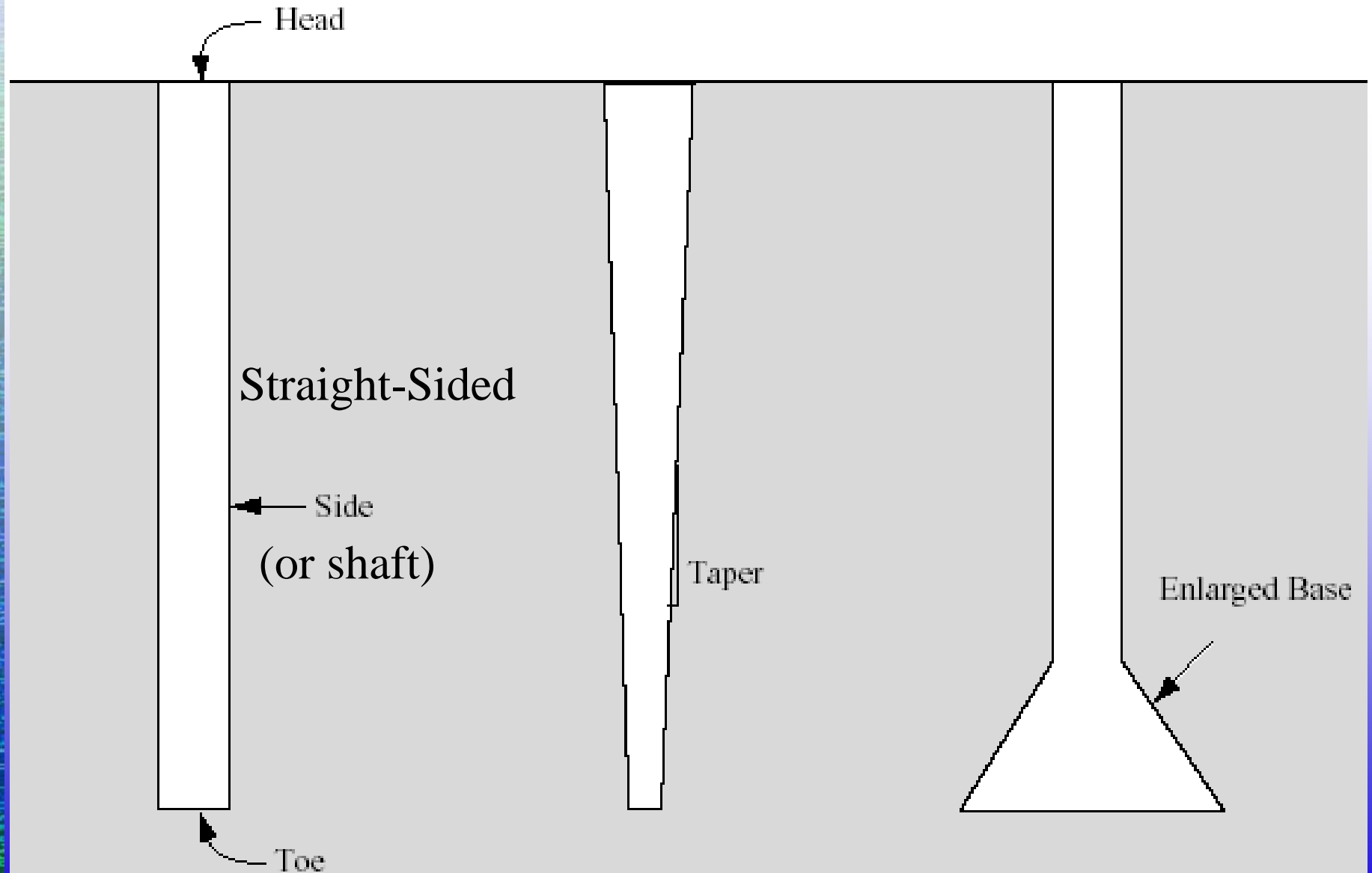

Driven Piles

A long, slender, prefabricated structural member driven or otherwise inserted into the ground



History of Driven Piles

- The oldest form of deep foundation in existence
- All ancient civilizations (Greek, Roman, Chinese) used driven piles to support structures in poor soils
- Driving equipment involved positioning, raising and lowering the driver by hand



Caesar's Bridge over the Rhine

- Built in a span of ten days
- Consisted of batter piles for the lateral loads of the river

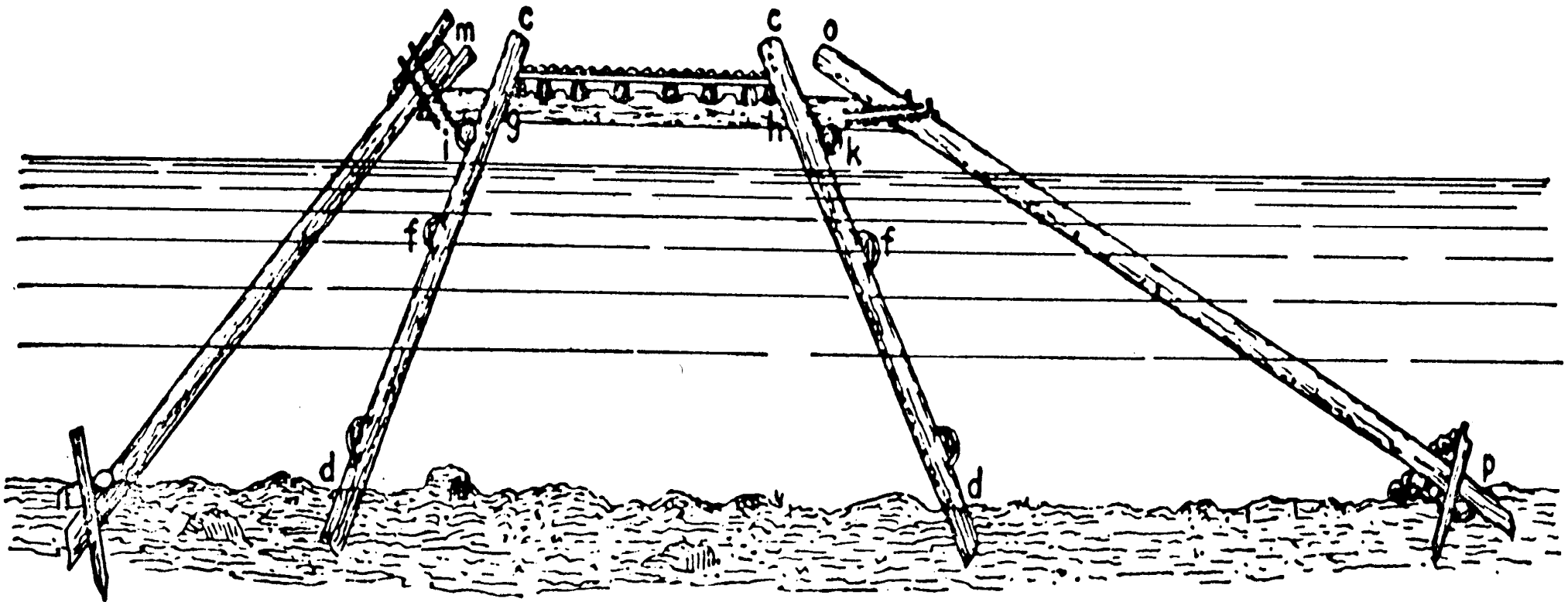

Advances in Driven Piles and Pile Drivers

- Piles
 - Steel Piles
 - H-Piles – addressed problems of bridge scour in the Midwest
 - Pipe Piles
 - Precast Concrete Piles
 - François Hennebique (1897) – first use
 - A.A. Raymond (1901) – built with it Raymond Concrete Pile Company
- Hammers
 - Steam Hammers
 - Naysmith (1845) – related to forging hammers
 - Vulcan (1887), MKT, etc.
 - Pile Driving Rigs
 - Raymond's Rotating Skid Rigs
 - Crawler mounted rigs

Types of Piles

- Selection of Pile Type
 - Applied Loads
 - Required Diameter
 - Required Length
 - Local availability of each pile type
 - Durability of the pile material in a specific environment
 - Anticipated driving conditions
- Types of Piles Used
 - Timber Piles
 - Steel Piles
 - H-Beams
 - Pipe Piles
 - Concrete Piles
 - Precast Piles
 - Prestressed Piles
 - Other Types of Piles
 - Plastic-Steel Composites
 - Sheet Piling

Timber Piles

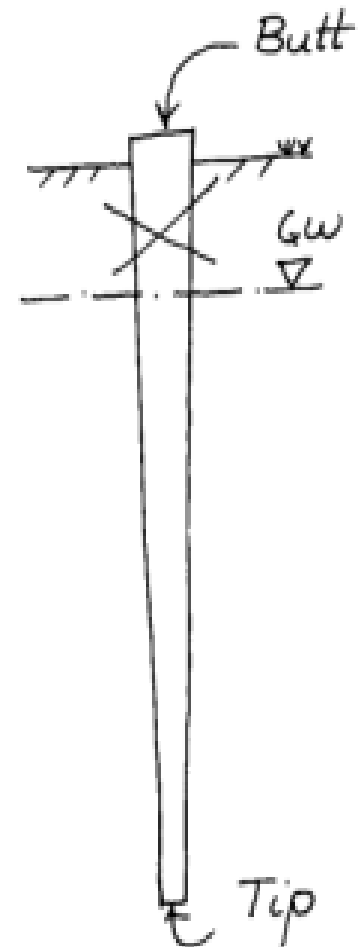

- + Inexpensive
Easy to cut
- Difficult to splice
(limited length)
Will rot above the
ground water level
if not treated
Marine borers
Limited bearing capacity
($< 250 \text{ kN}$)
Usually $100\text{-}200 \text{ kN}$
 $4\text{-}8 \text{ MPa}$

Soft clay
Loose sand and silt
below ground water level

- The oldest type of pile in use
- Most used today are Southern Pine or Douglas Fir
- Diameters range from 150 to 450 mm (6" – 18")
- Lengths from 6 to 20 m (20' – 60')

Steel Piles

- Steel piles first came into use in the 1890's
- Can be driven through hard soils and carry large loads
- Especially useful for tension and uplift loads
- Easy to splice and add onto
- Expensive compared to other piles
- May be subject to corrosion, depending upon soil and water conditions

H-Piles

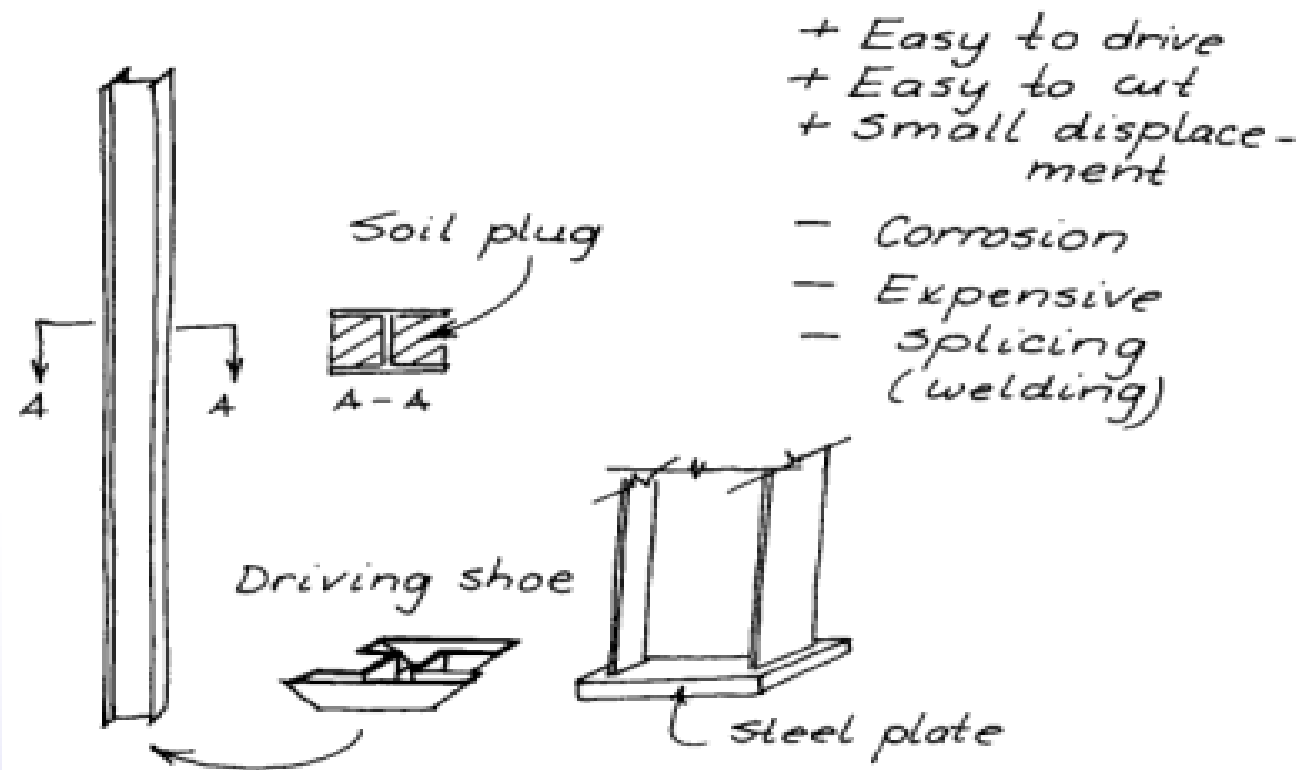

- Similar to WF beams used in structural applications but flanges and webs are of equal thickness with H-beams
- Typically 15-50 m (50 – 150') long
- Working axial loads of 350 to 1800 kN (80 – 400 kips)
- Often used as end bearing piles in rock

Pipe Piles

$450 \text{ kN} < Q < 7000 \text{ kN}$

Steel pipe piles.

Offshore structures

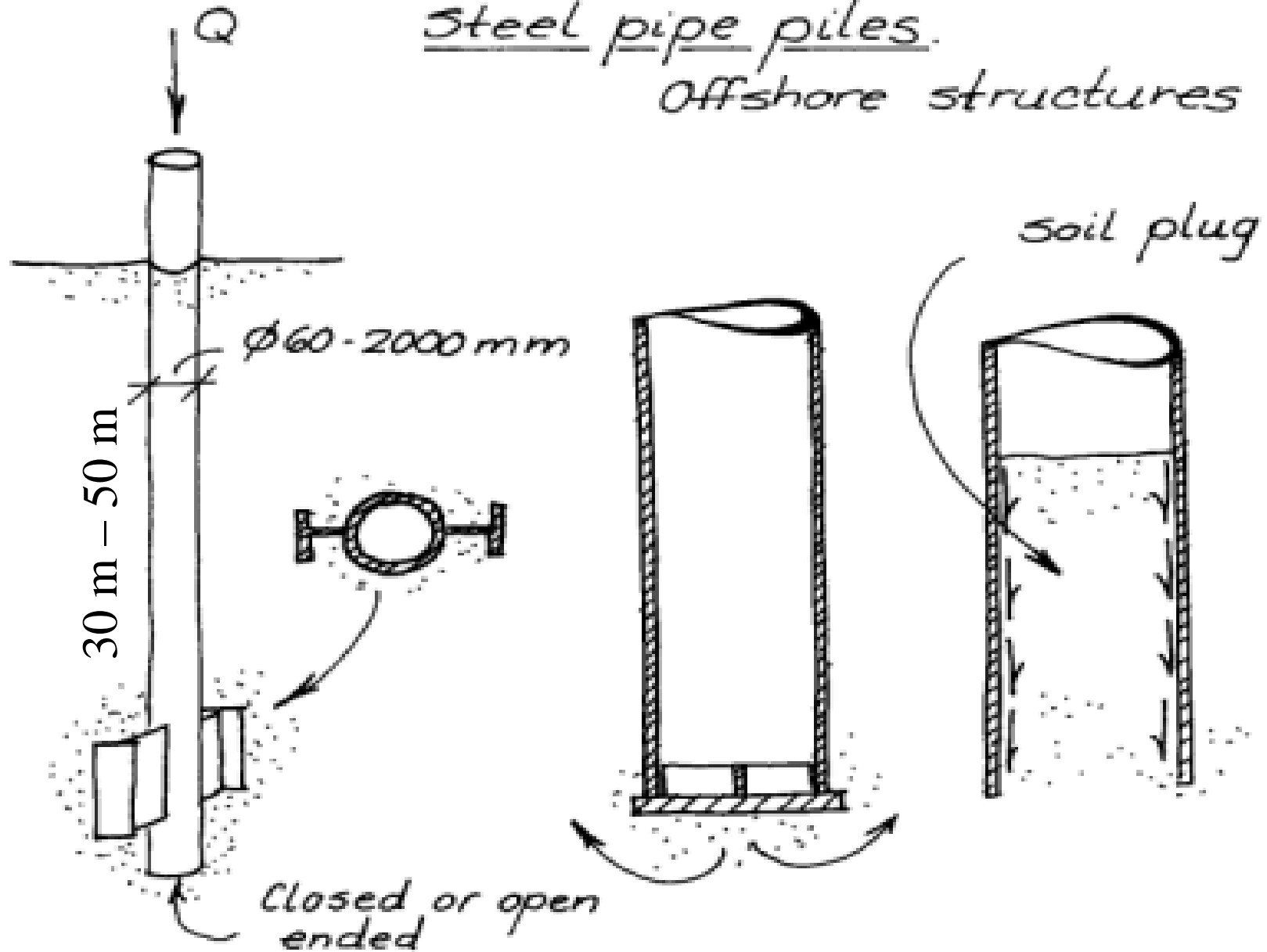

Splicing Pipe Piles

- For large pipe piles, add-on is lifted and lowered onto existing piles
- Piles chamfered so that welding can be done between the sections
- After welding and inspection, driving can resume



Concrete Piles

- Either precast or prestressed piles
- Precast contain rebar similar to shallow foundations – not commonly used in North America
- Prestressed uses cables tensioned before concrete is poured

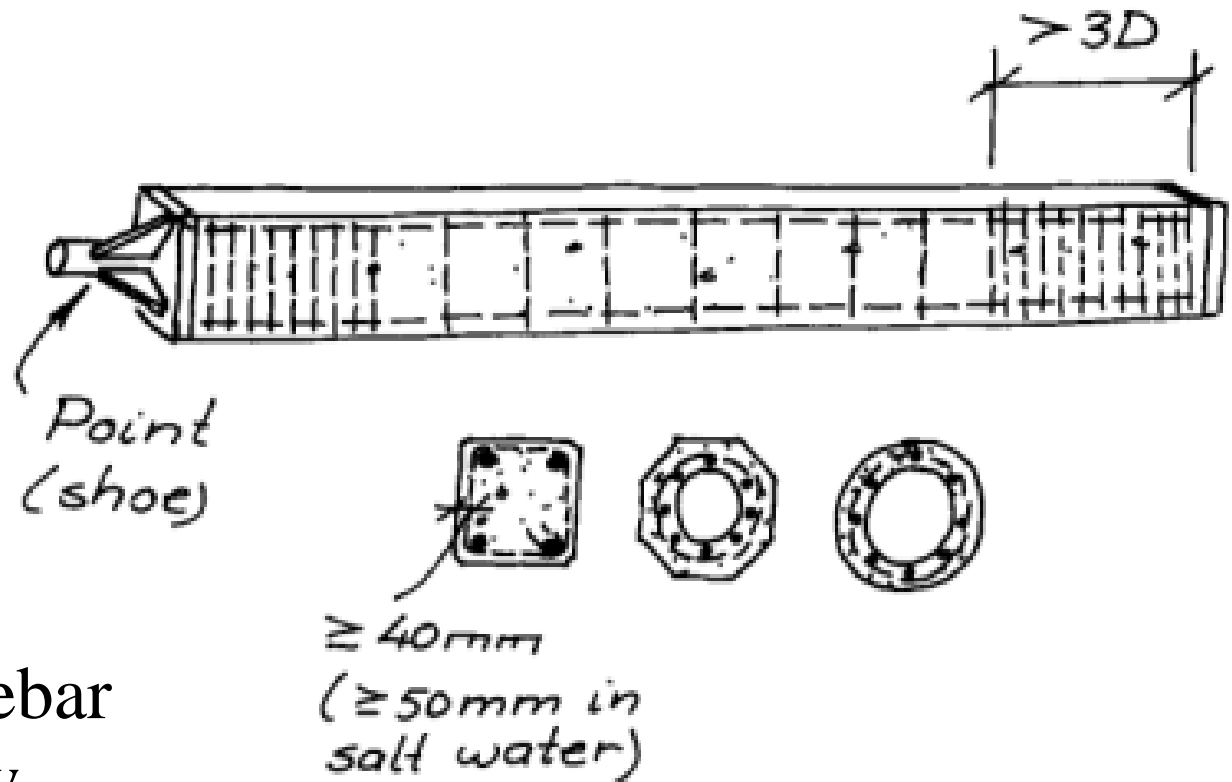

Cutting Concrete Piles

- Can be cut with concrete saws or special pile cutters
- Usually best to drive as friction piles where refusal is not as likely to take place



Composite Piles

- Two possible definitions
 - Pile made up of two other pile types, such as a concrete pile with an H-pile "stinger" on the end
 - Pile made up of two materials
- Plastic-steel composite
 - A useful substitute for wood piles in applications where wood is environmentally unacceptable



Installation Equipment for Driven Piles

- Pile Driving Rigs
- Pile Hammers
- Hammer Accessories
 - Leaders
 - Cushion Material
- Predrilling, Jetting and Spudding



Pile Hammers

- Impact Hammers
 - Drop Hammers
 - Air/Steam Hammers
 - Diesel Hammers
 - Hydraulic Hammers
- Vibratory Hammers
- Pile Jacking Devices



Drop Hammers



- Oldest type of hammer in use
- Simply raised by the crane and released to impact the pile top
- A very simple hammer, yet slow and efficiency is inconsistent

Air/Steam Hammers



- In use since the nineteenth century
- Hammers are simple; require little maintenance and are of long duration
- Efficiency also variable due to age of hammers and conditions of operation
- Hammers can be single, double or differential acting

Diesel Hammers

- Developed in Germany between the two World Wars
- Does not require an external power source; usually light
- Can also be single-acting or double-acting



Operating Cycle of Diesel Hammers

- Upstroke or starting of the hammer with starting device (crab)
- Lowering of ram; injection of fuel
- Combustion at bottom of stroke
- Fuel ignition and upward lifting of ram

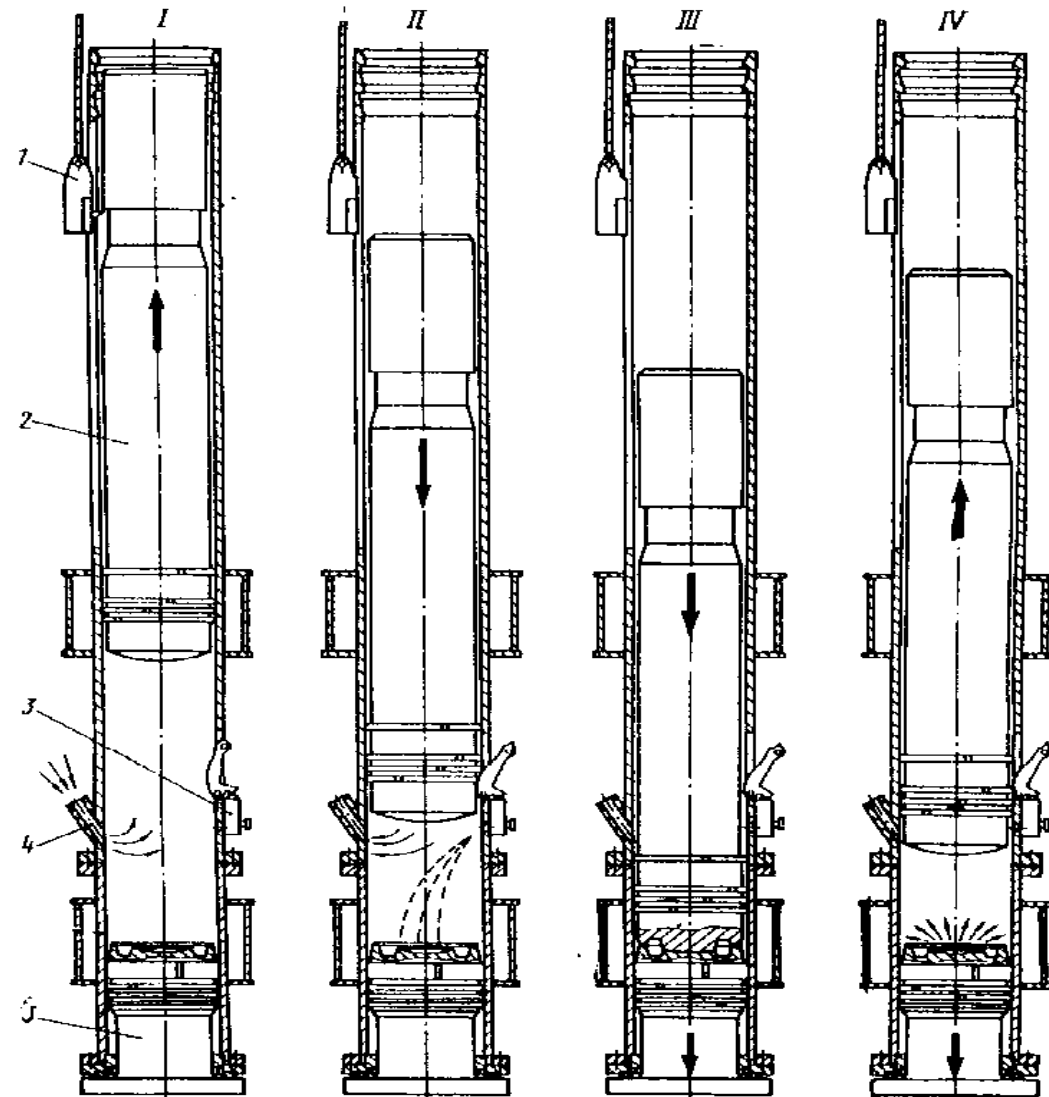

Hydraulic Hammers



- Newest type of impact hammer
- Uses hydraulic fluid to move the ram up and down
- Usually has some kind of downward assist
- Incorporate energy and blow rate control, along with data recording



Vibratory Hammers

Pile Jacking Device

- Installs piling by pushing them into the soil, not impact
- Useful in situations where vibrations cannot be tolerated

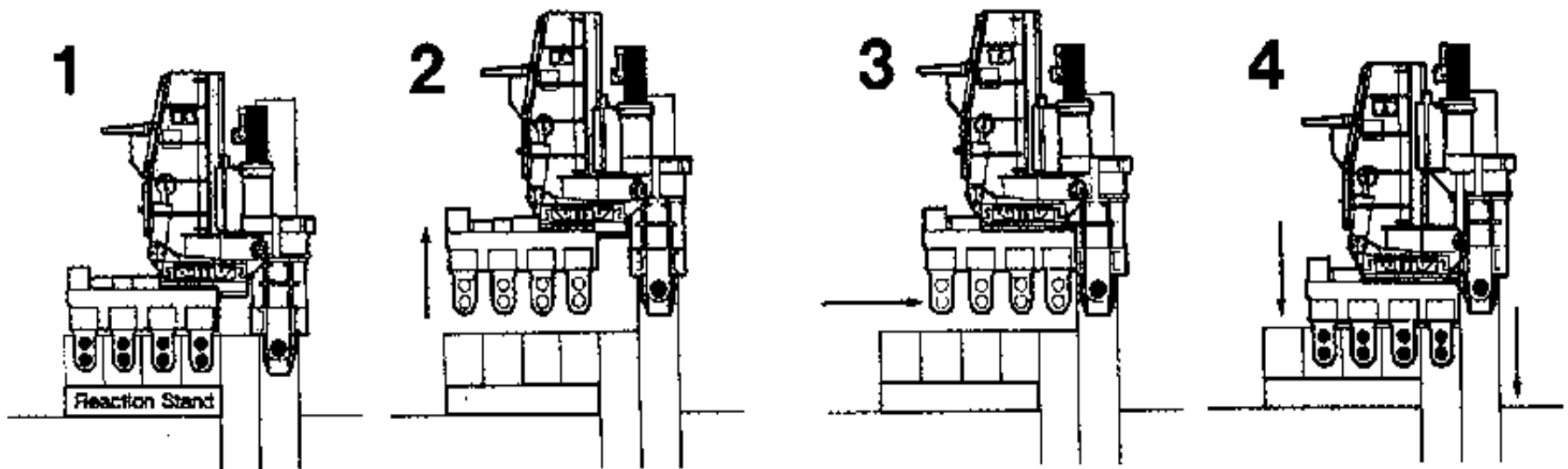

Driving Accessories

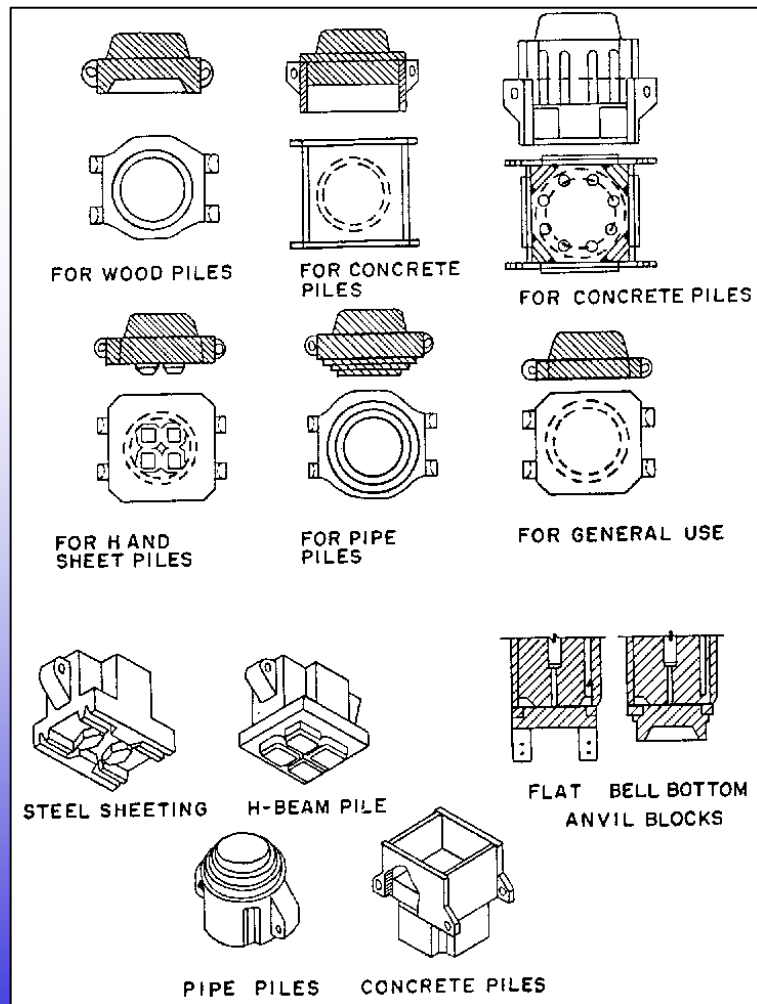

- Drive Caps
 - Mate the hammer to the pile
 - Hold the cushion material in place
 - Weight of the cap influences the energy transmission from the hammer to the pile

Cushion Material

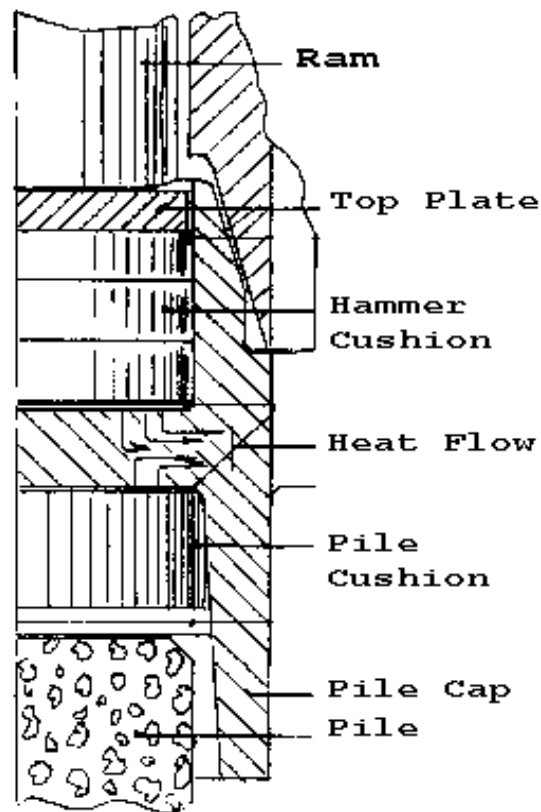

Air-Steam Hammers
Integral Ring

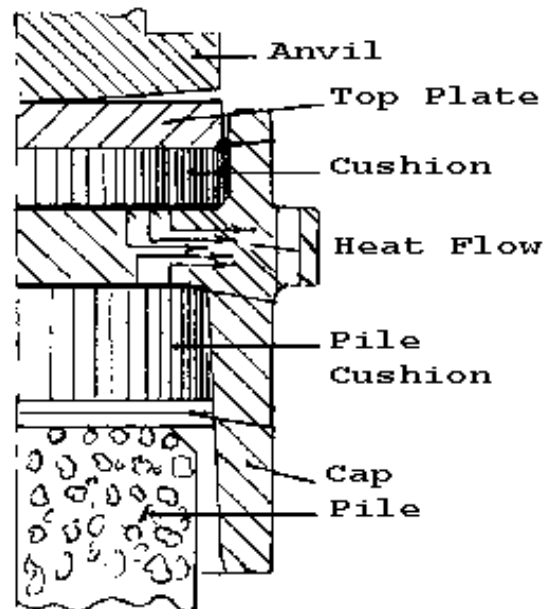

Diesel Hammers

- Hammer Cushion
 - Protects the hammer and modulates the blow
 - Usually struck via a top plate above
- Pile Cushion
 - Used only with concrete piles
 - Protects the pile from cracking and spalling

Leaders

Fixed Leaders

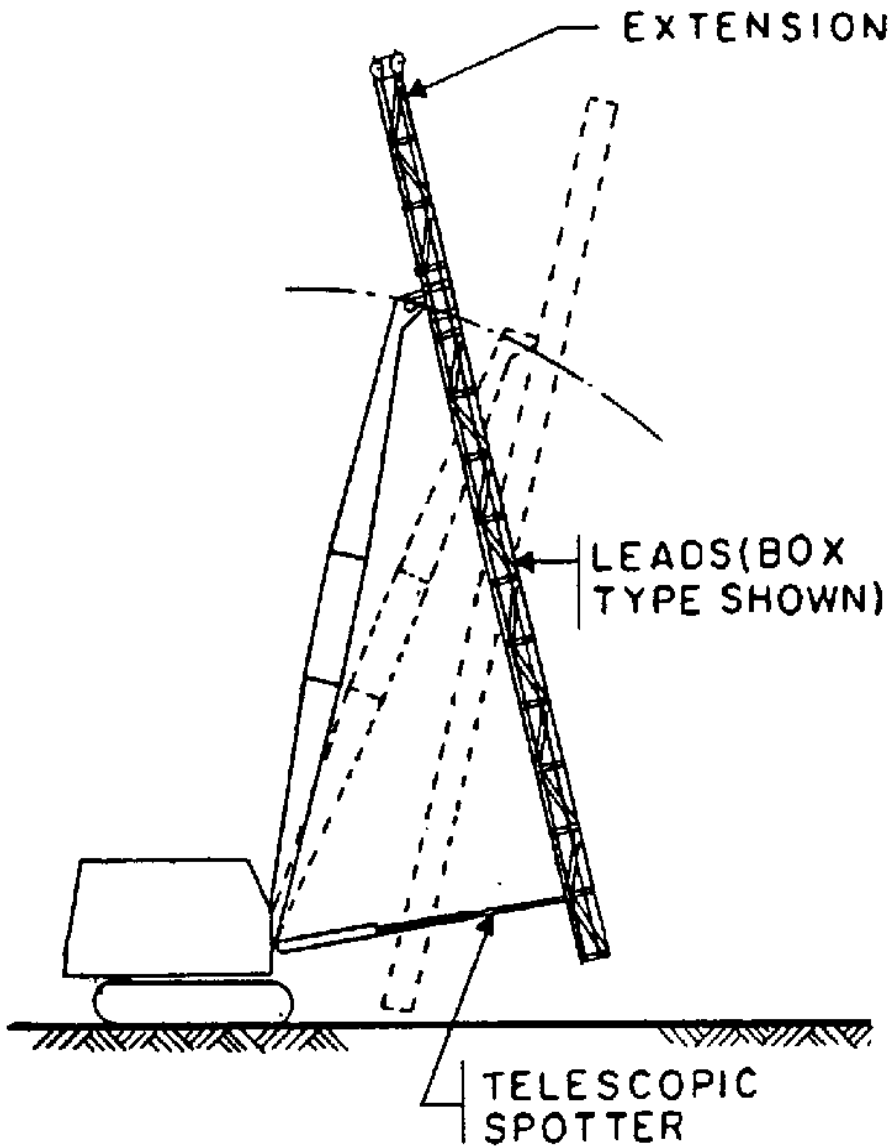

Swinging Leaders

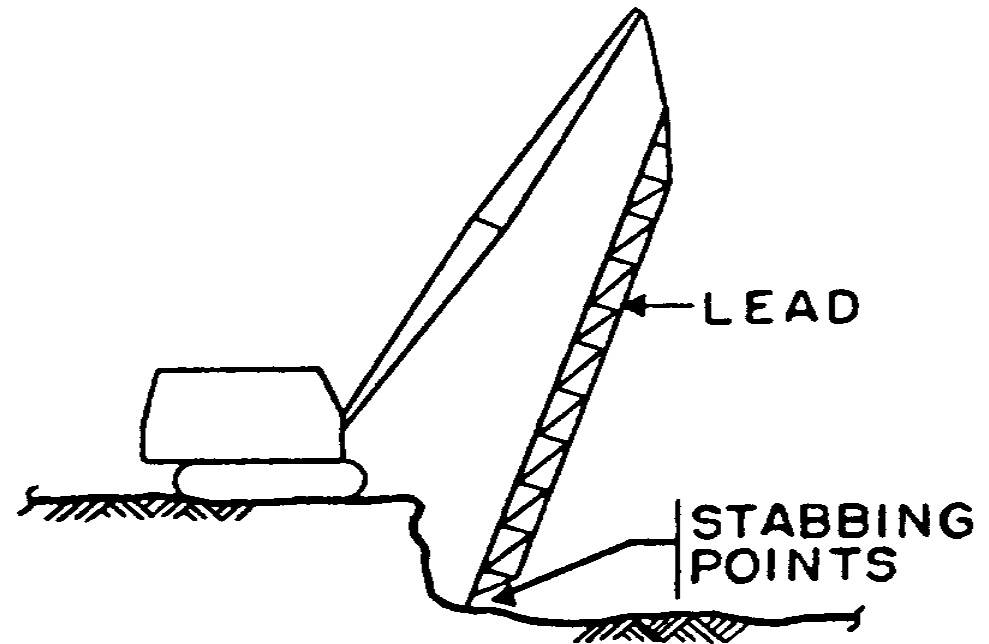
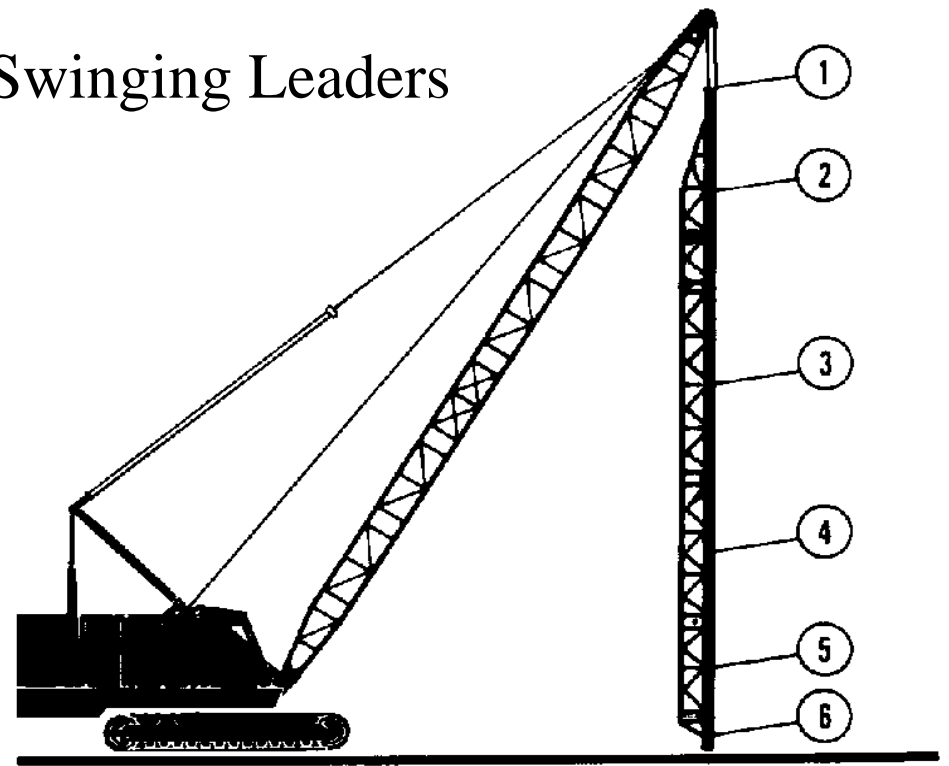

Swinging Leaders w/Batter Pile

Predrilling, Jetting and Spudding

- Methods of reducing the soil resistance to assist driving
- Predrilling
 - Using an auger (usually continuous flight) to drill a hole into which the pile is driven
 - Does result in loss of shaft friction
- Spudding
 - Driving a hard metal point into the ground, then removing and driving the pile
 - Rarely used

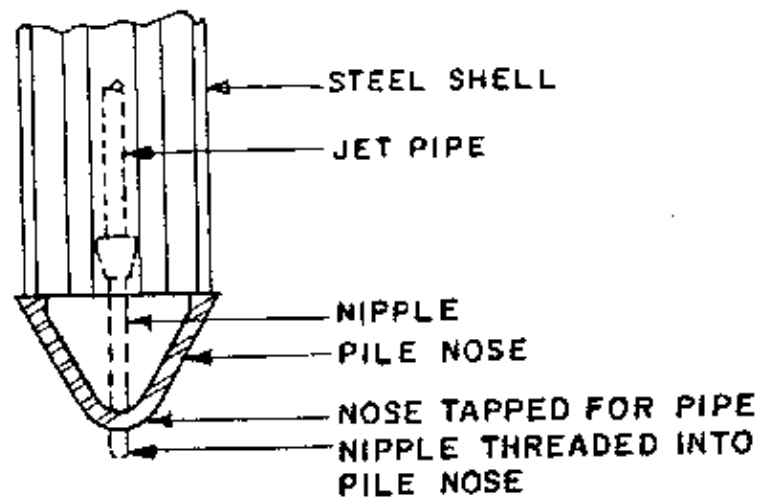

STEEL SHELL - INSIDE JET
(a)

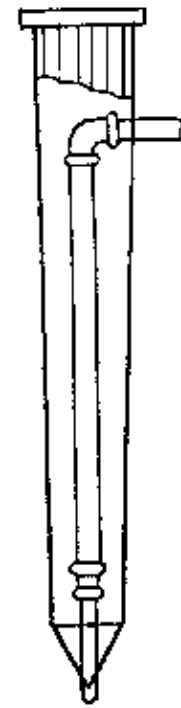

Jetting

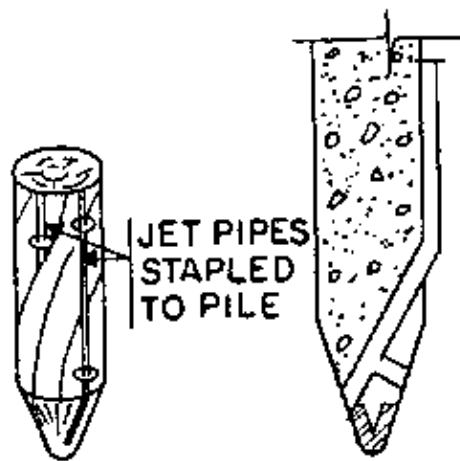

WOOD PILE JET
(b)



(c)

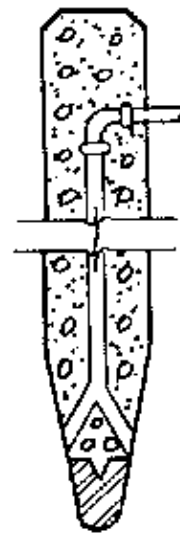

CONCRETE PILE JET
(d)

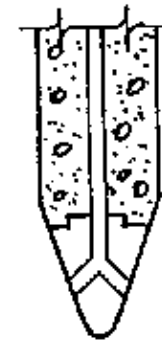

(e)

JET PIPE
SUSPENDED FROM
LEADS & WORKED
UP & DOWN AS
REQ'D.

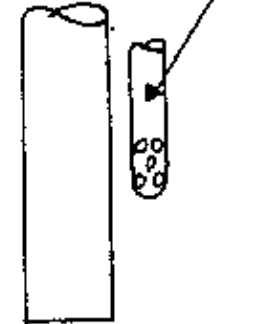

OUTSIDE JET
(f)

Mandrel-Driven Thin Shelled Piles

- Thin shelled steel piles which are driven with the assistance of a mandrel, as they would collapse if driven directly (as with pipe piles)
- Piles then filled with concrete and a reinforcing cage
- First widely popular mandrel driven thin shelled pile was the Raymond Step-Taper Pile, but there are many other kinds available today

Mandrel-Driven Thin Shelled Piles

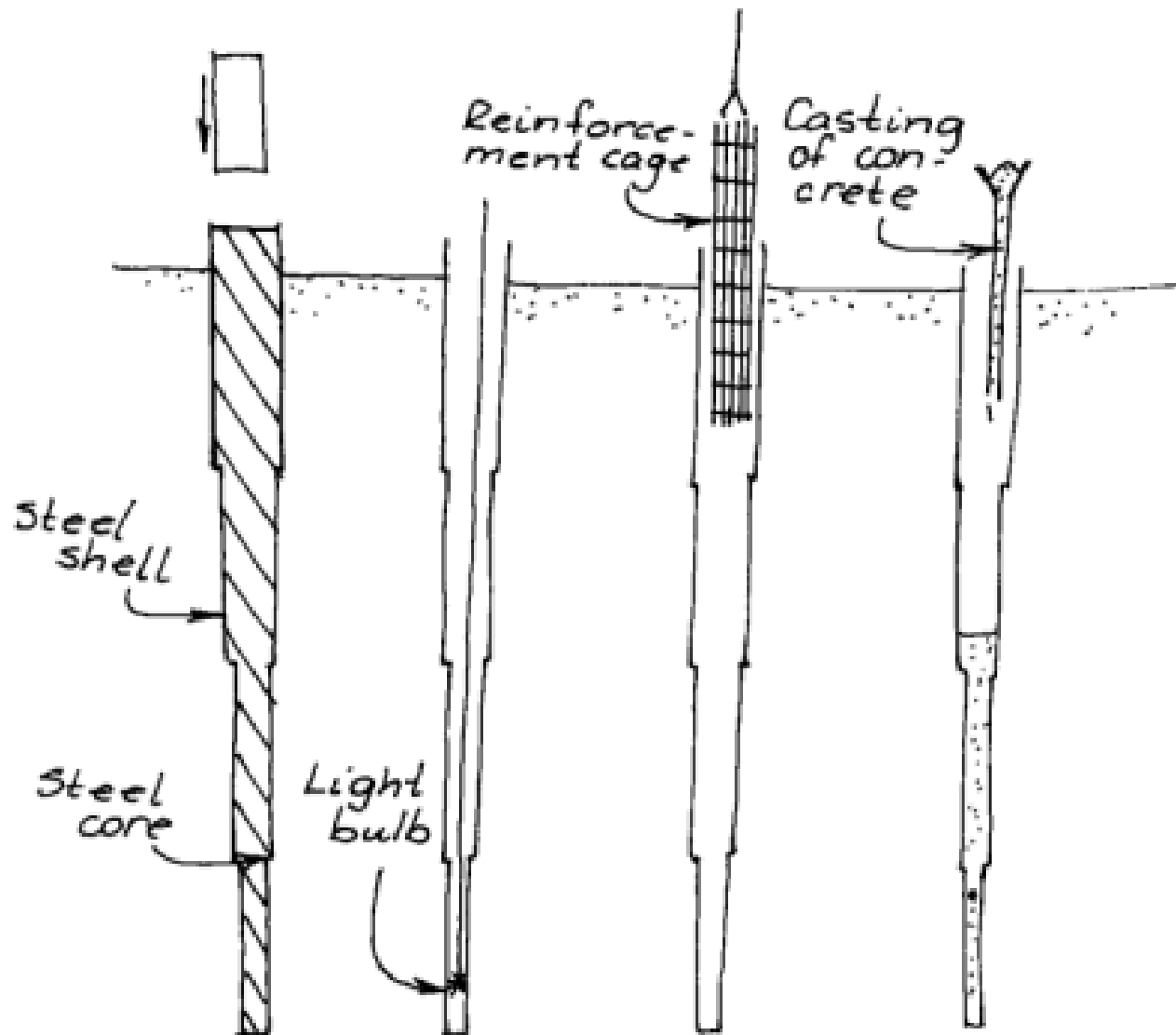

Applications for Driven Piles

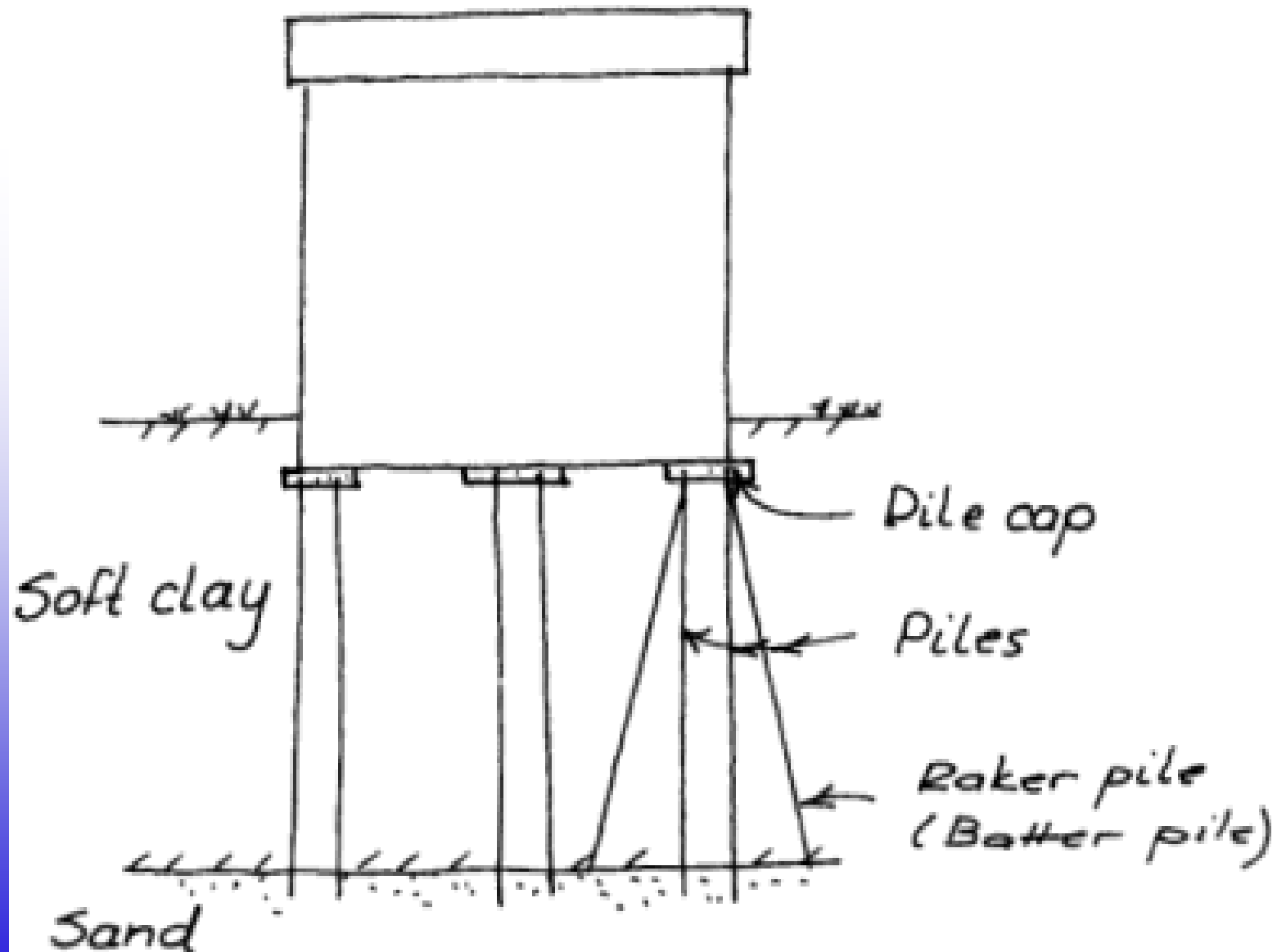

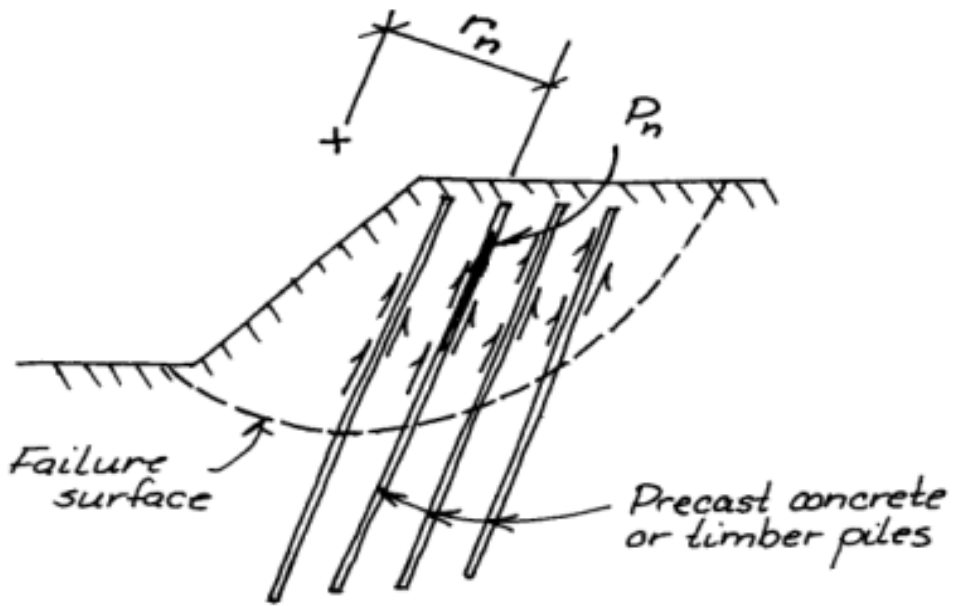

Slope stability.

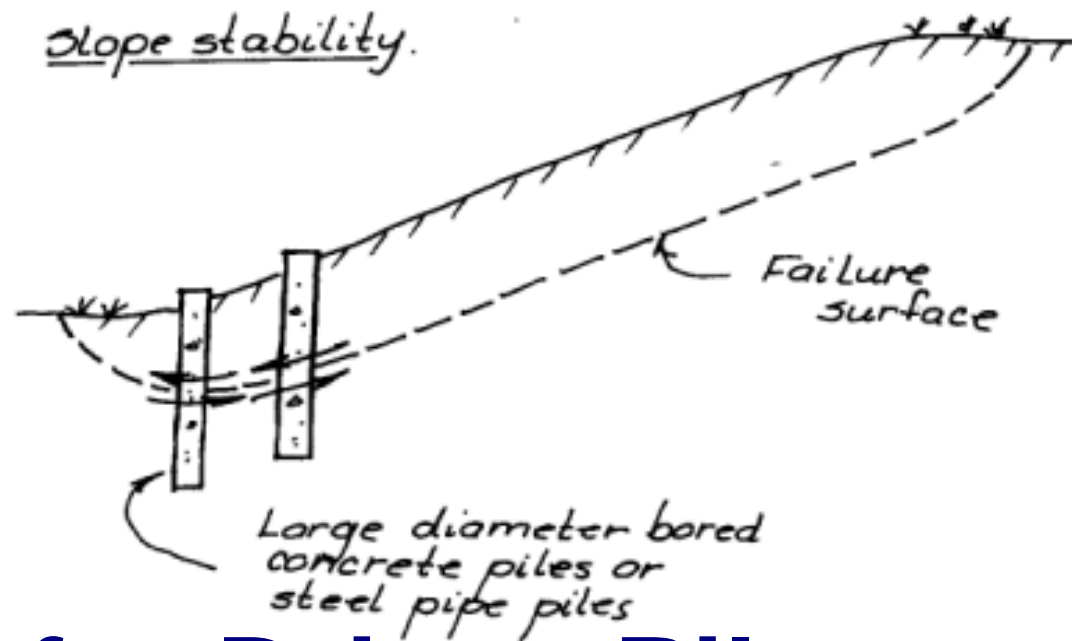

Applications for Driven Piles

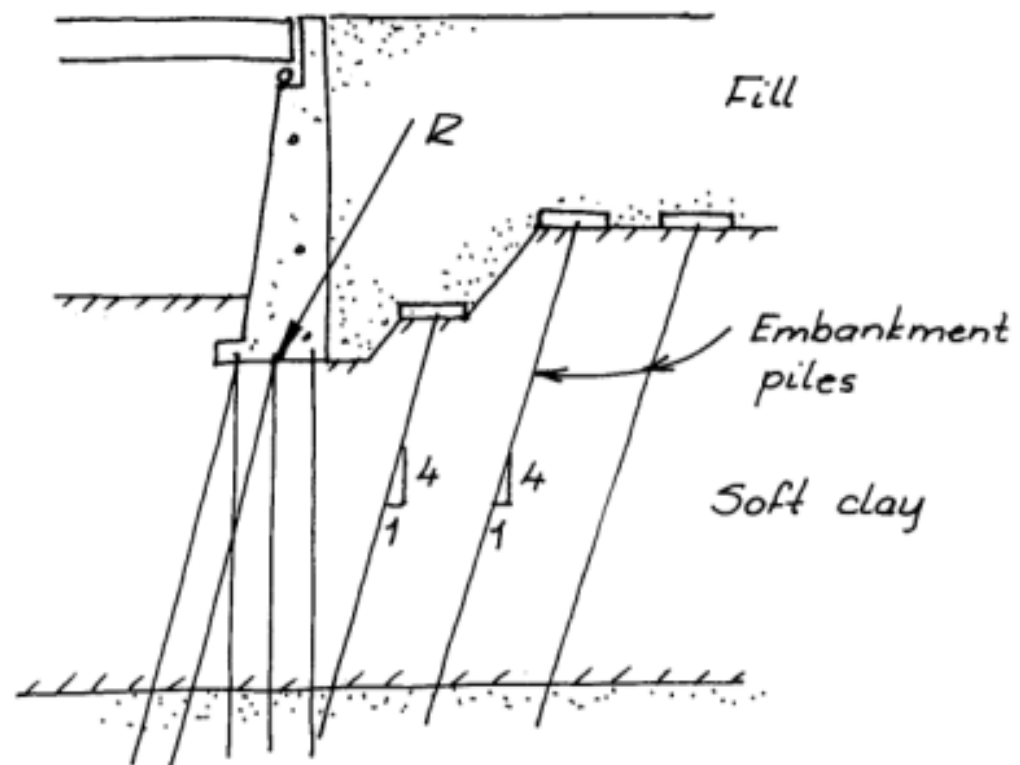
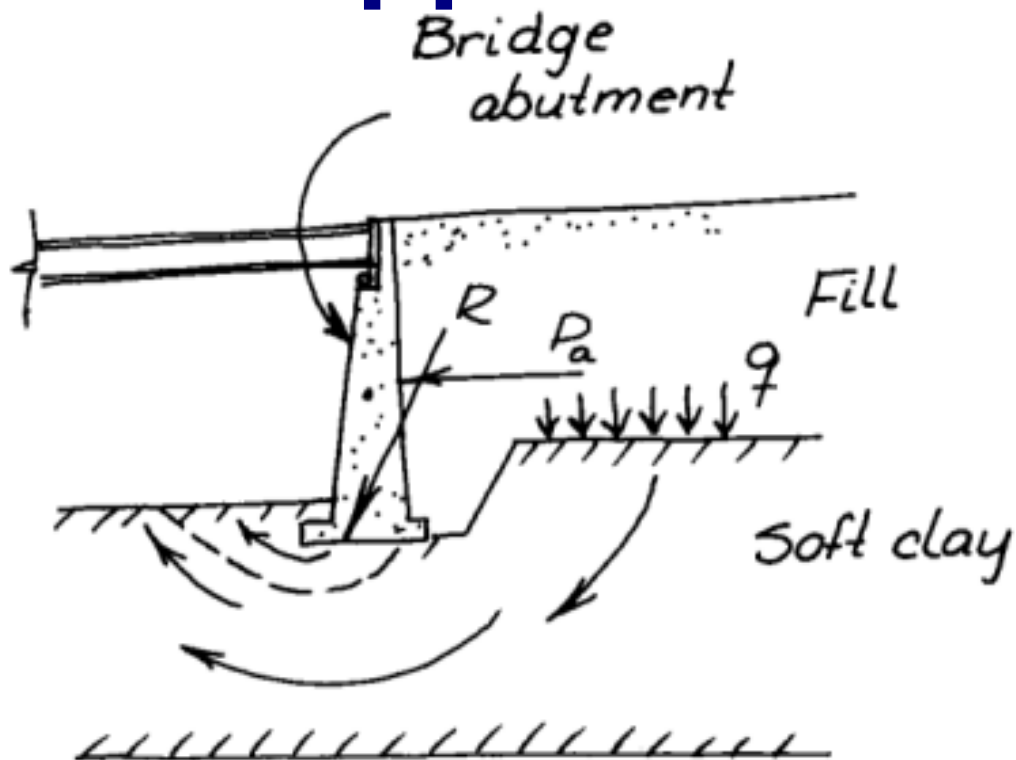

Drilled Shafts

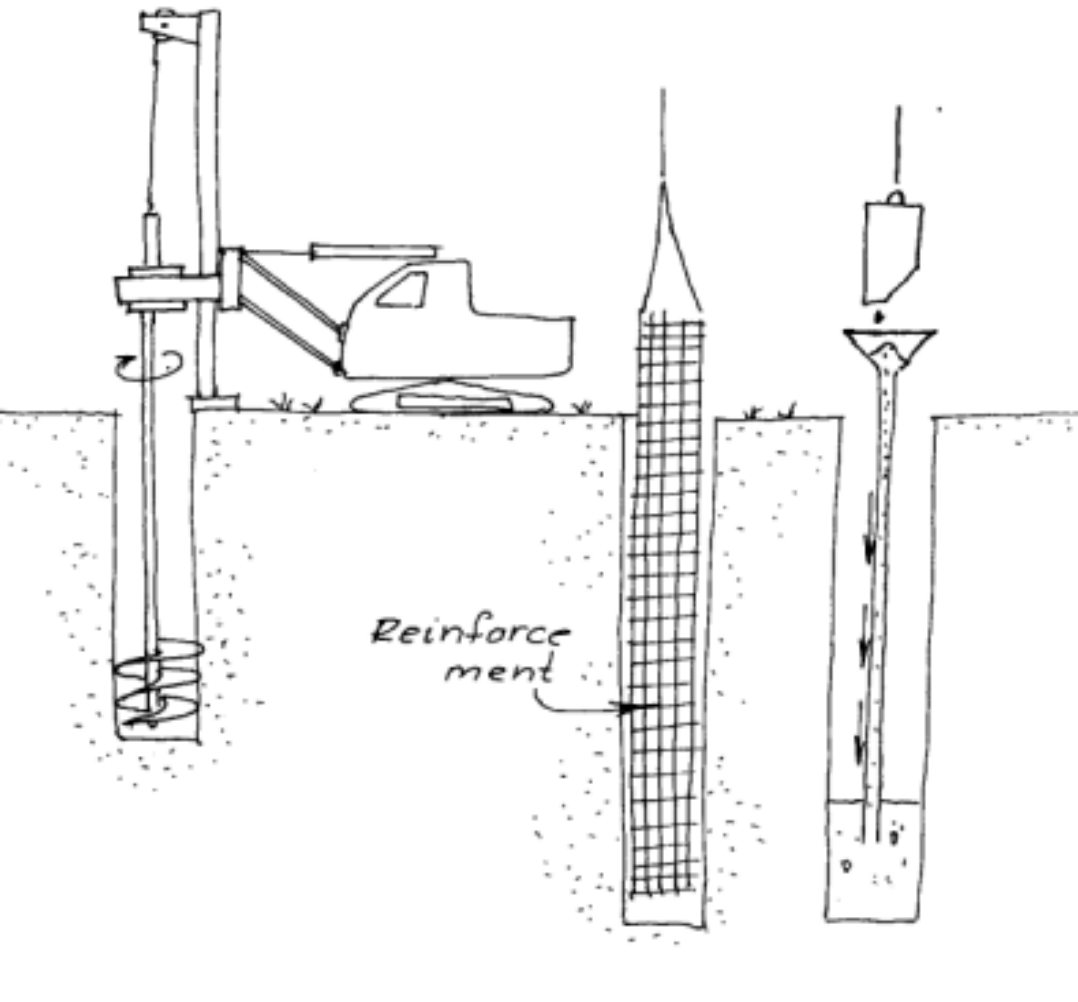

- Other terms
 - Pier
 - Drilled pier
 - Bored pile
 - Cast-in-place piles
 - Caisson
 - Drilled Caisson
 - Cast-in-drilled-hole (CIDH) foundation

Drilled Shafts

- Procedure
 - Using a drill rig, excavate the shaft to the required depth
 - Fill the lower end of the shaft with concrete
 - Place a prefabricated reinforcing steel cage inside of the shaft
 - Fill the shaft with concrete
- Similar to mandrel driven piles except hole is created by drill rig
- Dry method is only applicable to competent, non-caving soils

History of Drilled Shafts

- Started as an extension of shallow foundations; until 1920's most were hand dug
 - Chicago Well Method used a wooden "barrel" form to prevent collapse of the soil
- Drilling rigs first used in states with oil drilling, whose technology was applied to shaft drilling
- Technology of cutting tools, casing and drilling mud, then advanced on its own
- Drilled shafts are widely used today in a wide variety of geographical areas

Advantages of Drilled Shafts

- Mobilisation and demobilisation costs are in many cases lower
- Construction process generates less noise and vibration
- Diameter and length of the shaft can be changed during the job more easily
- With proper cutting tools, can penetrate through cobbles and boulders and even in to rock
- Shafts can be large and columns can be supported with one shaft as opposed to multiple

Disadvantages of Drilled Shafts

- Successful construction depends upon the quality control and skill the contractor can exercise on the pour; defects are usually not visible and can be serious
- Driving piles pushes soil aside, thus increasing capacity of piles of same size (both shaft and toe)
- Full scale load testing is mandatory to determine actual load bearing capacity of drilled shafts; this is being mitigated by dynamic (CAPWAP) and semi-dynamic (Statnamic) methods

Equipment for Drilled Shafts



- Most drilled shafts are 500 – 1200 mm (18"-48") in diameter and 6 – 24 m (20'-80') in length
- Most are drilled with a truck mounted rig; specialised rigs are used for longer and larger shafts
- The flight auger used is a helix-shaped drill bit with a relatively short flight
- For rock, hardened teeth can be added to the end of the auger to enhance rock drilling capabilities

Drilled Shafts in Firm Soils

- Firm soils offer a relatively straightforward material into which to drill a shaft
- Holes are usually drilled without any special support
- After the holes are drilled, the reinforcing cage is inserted and the hole filled with concrete
- Caving is usually not a problem in firm soils
- If drilling under the groundwater table, water is pumped out as the hole advances and concrete is placed in dewatered shaft

Drilled Shafts in Caving or Squeezing Soils

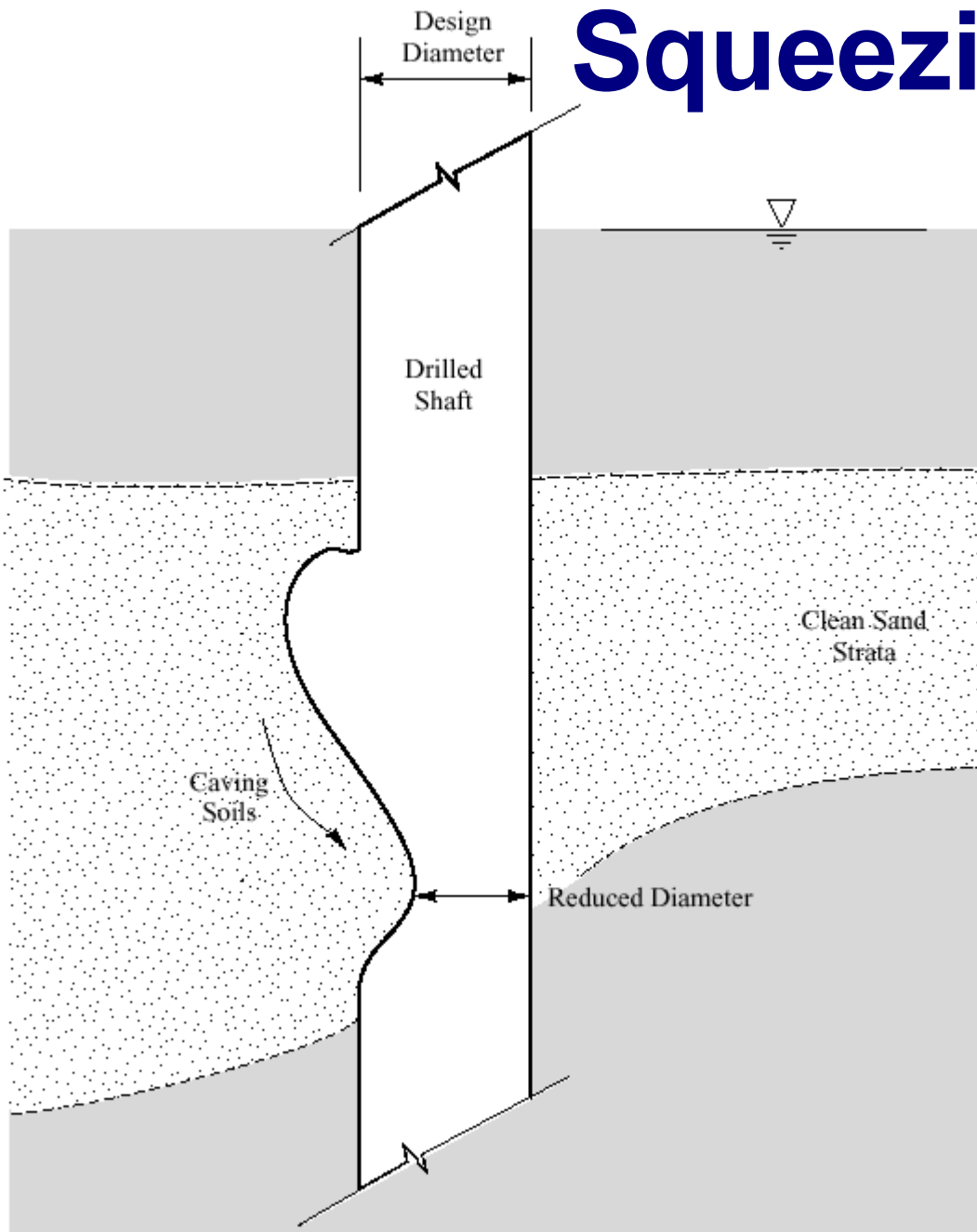

- Soft or caving soils present serious problems for conventional drilled shafts
- Solutions
 - Casing Method
 - Use of drilling fluid (Slurry Method)

Casing Method

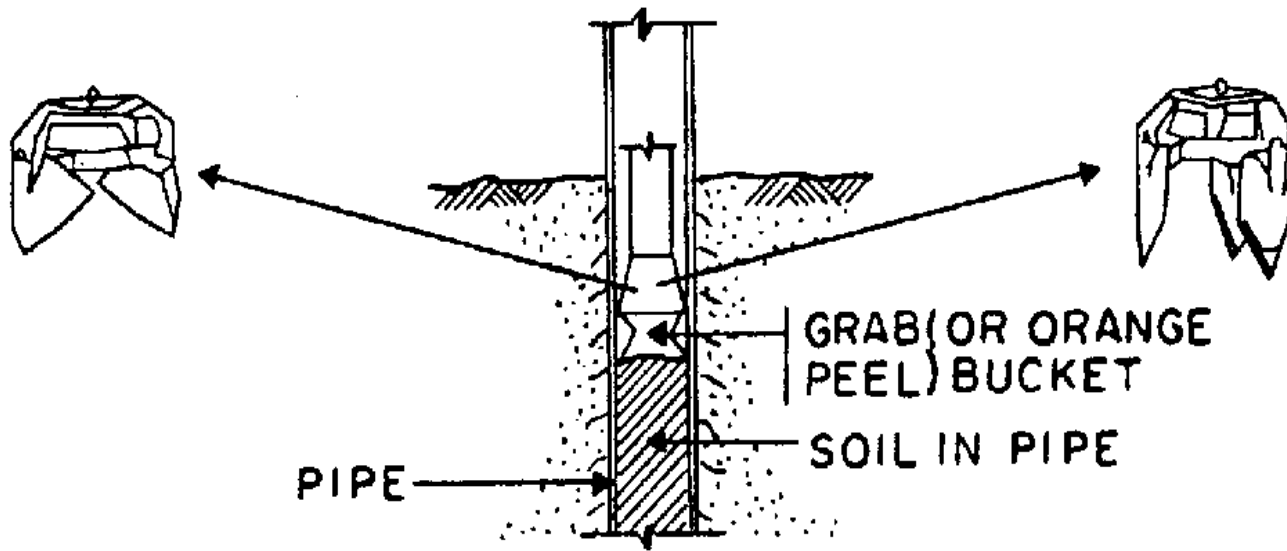

Casing is frequently installed using a vibratory hammer

Turning is desirable during installation but in many cases not absolutely necessary

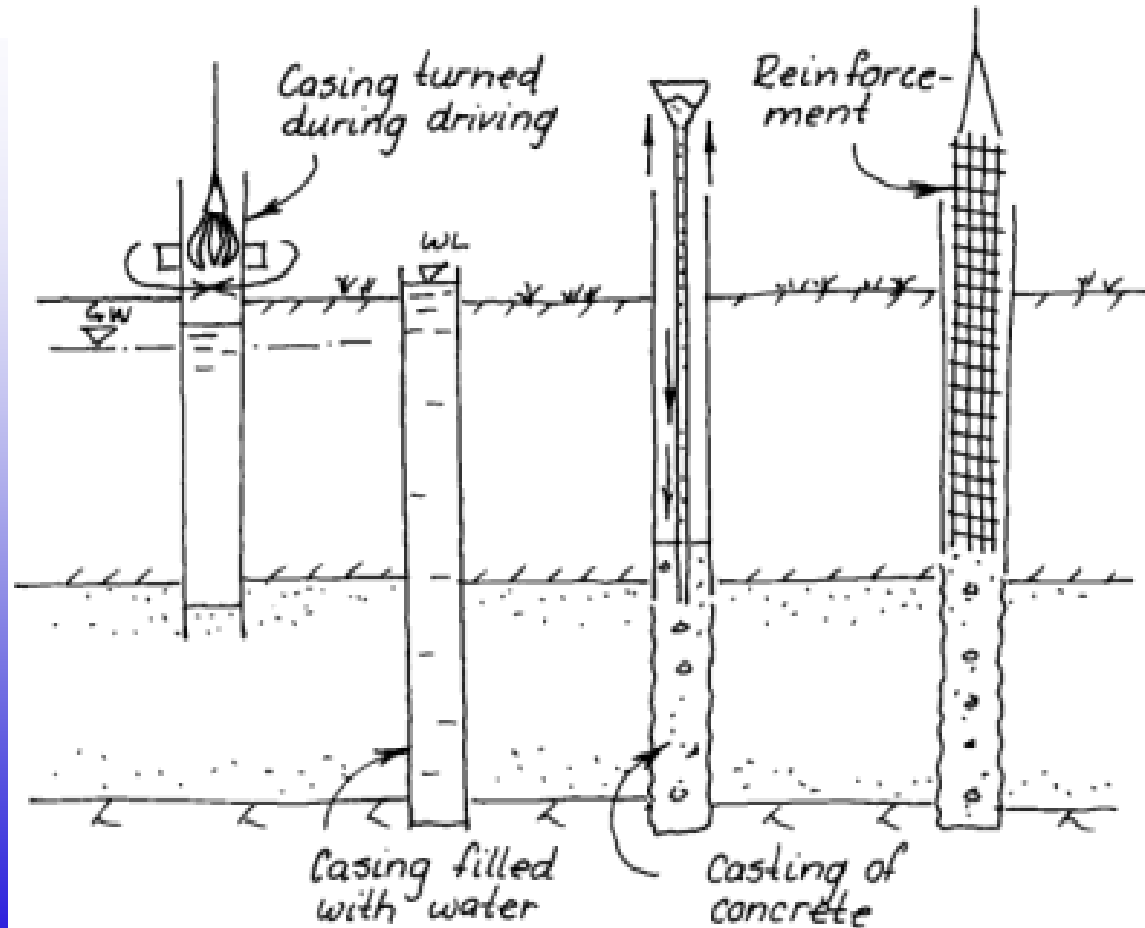

Slurry Method

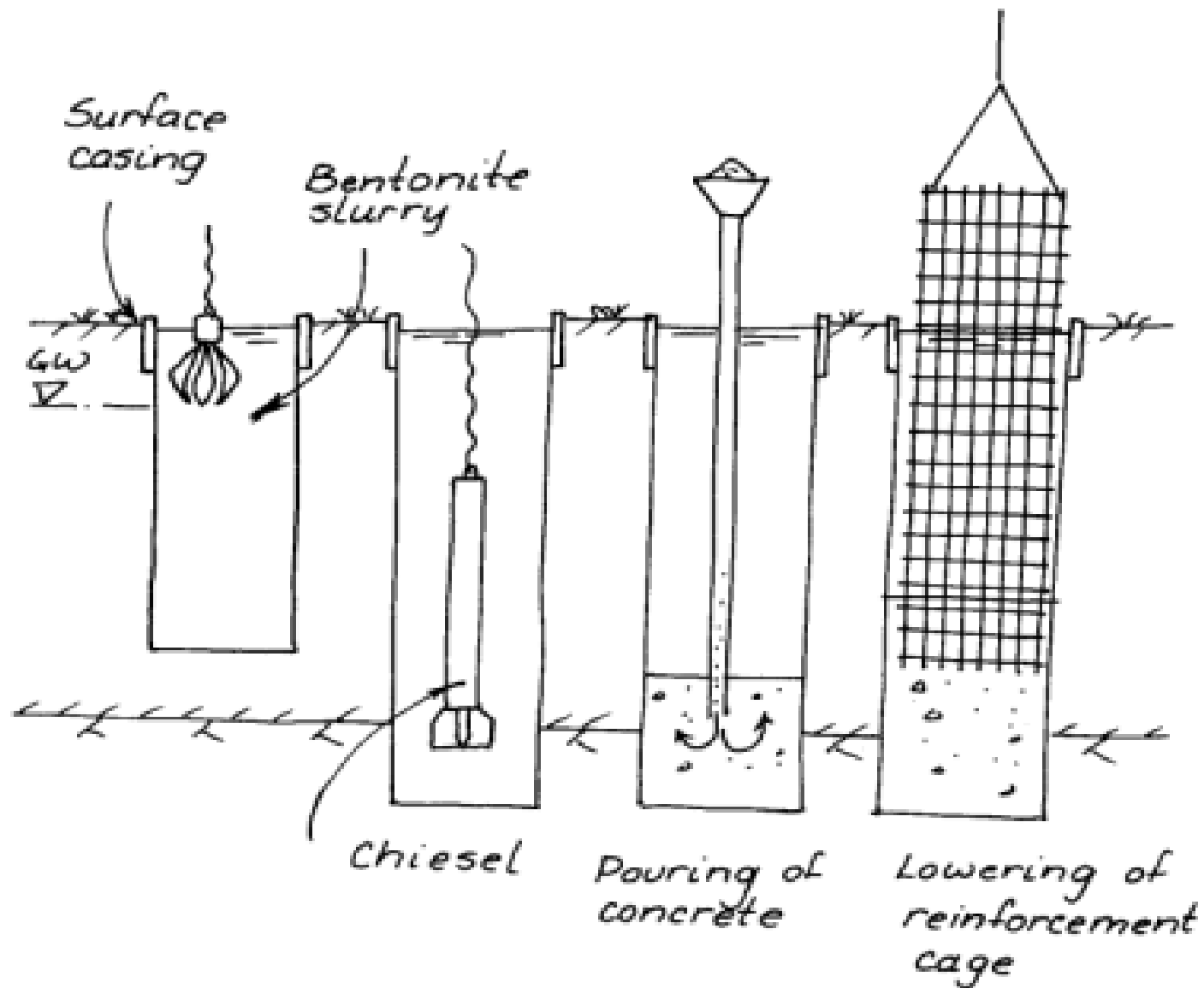

Underreamed (Belled) Shaft

Cleaning out the bell at the bottom of the shaft can be a dangerous operation

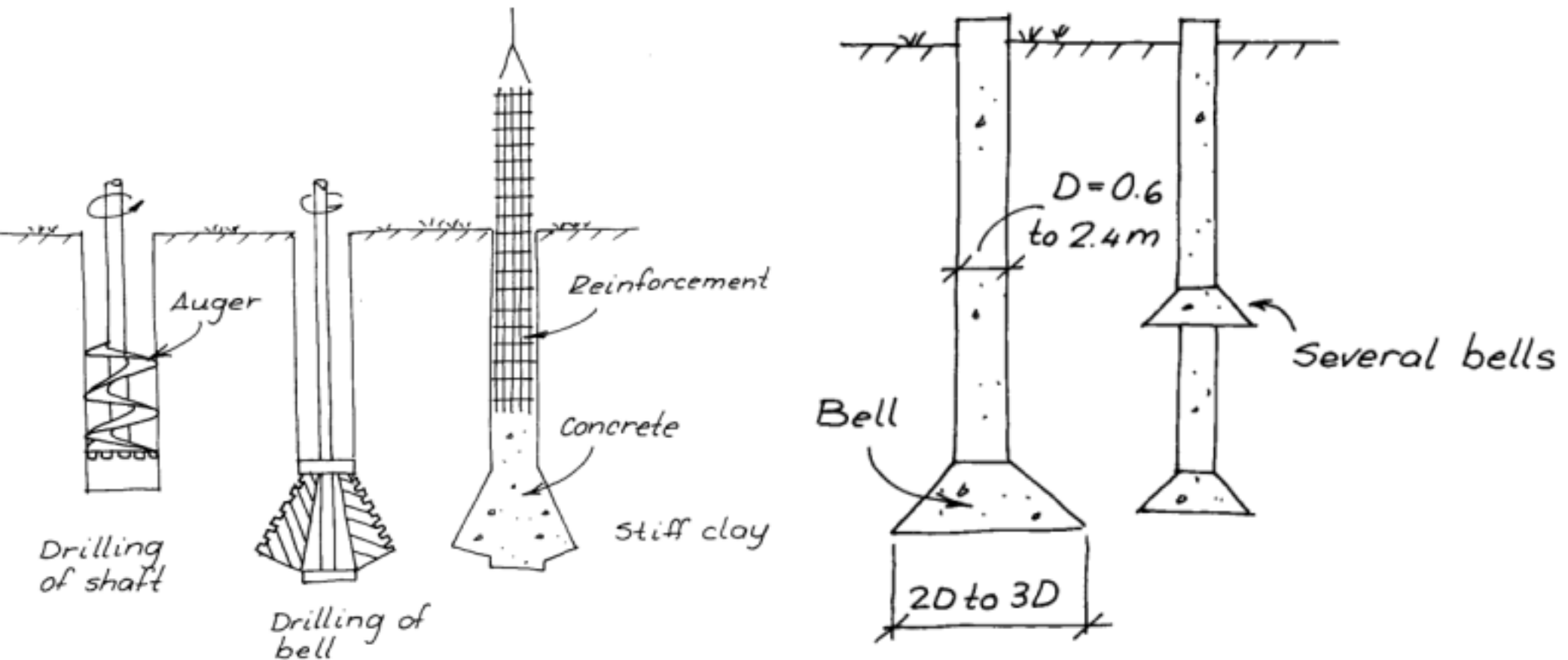

Caissons

Open Caisson

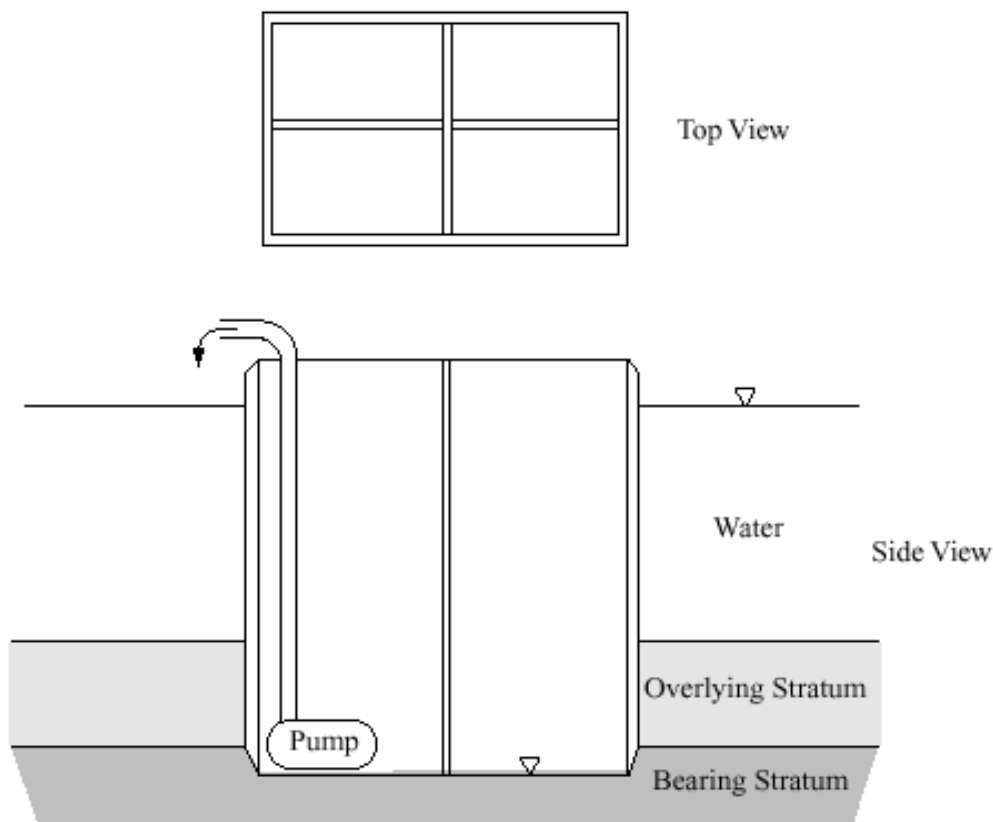

- A prefabricated hollow box or cylinder which is sunk into the ground and then filled with concrete
- Are usually used in construction of bridge piers and other structure where the foundation is under water

Pneumatic Caissons

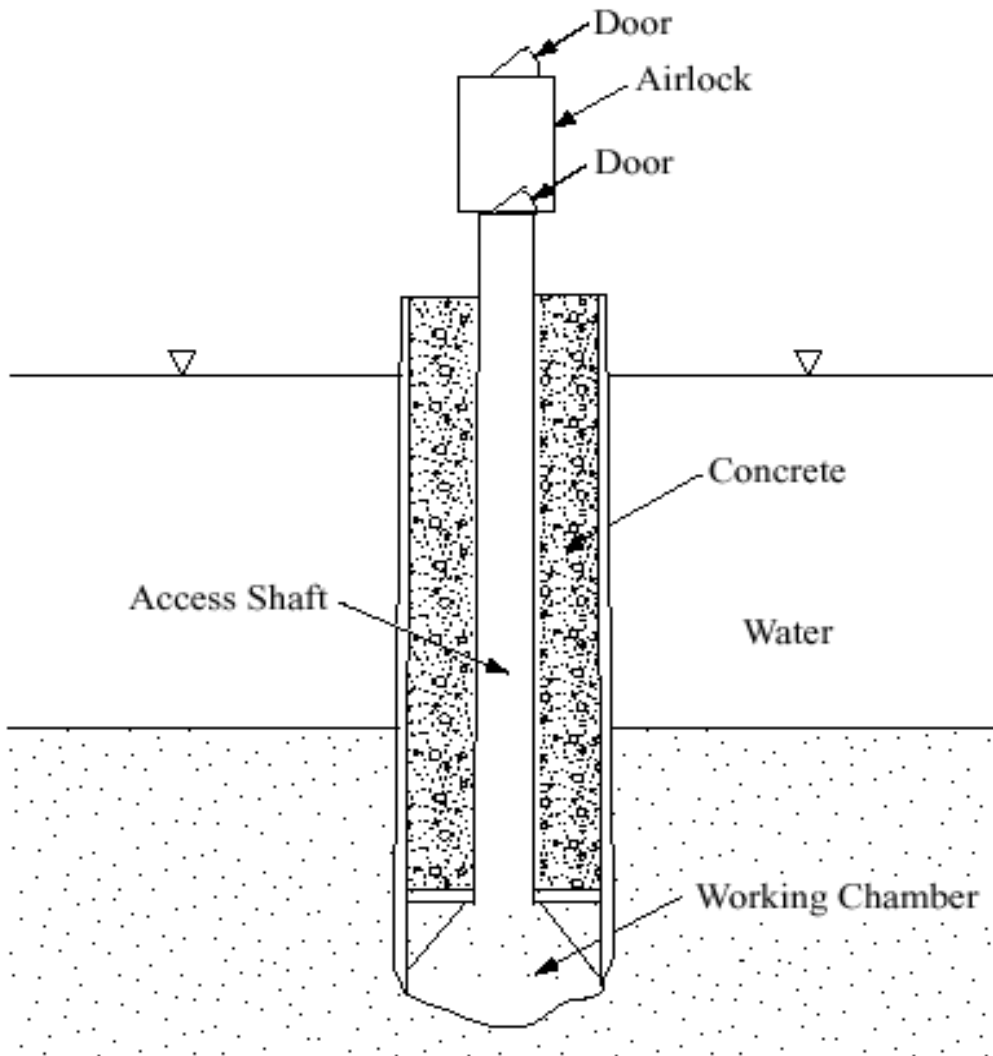

- Compressed air is used to keep water out and allow installation and construction in the dry
- High air pressures can and have created dangerous air conditions for workers, who must use an air lock

Auger-Cast Piles

- Using a continuous flight auger 300-400 mm (12-16") in diameter, drill a hole in the ground
- Typical depths are 6 – 15 m (20'-50') but can go up to 27 m (90')
- Inject cement grout through the hollow stem of the auger
- Slowly and smoothly raise the auger to the surface, forming the pile and bringing the cuttings to the surface
- Insert steel rebar cage and fill hole with concrete

Auger-Cast Piles

- Other names

- Augered Pressure Grouted (APG) Piles
- Augered cast-in-place pile
- Continuous flight auger pile
- Intruded mortar piles
- Augerpass Pile
- Auger Pile
- Grouted Bored Pile

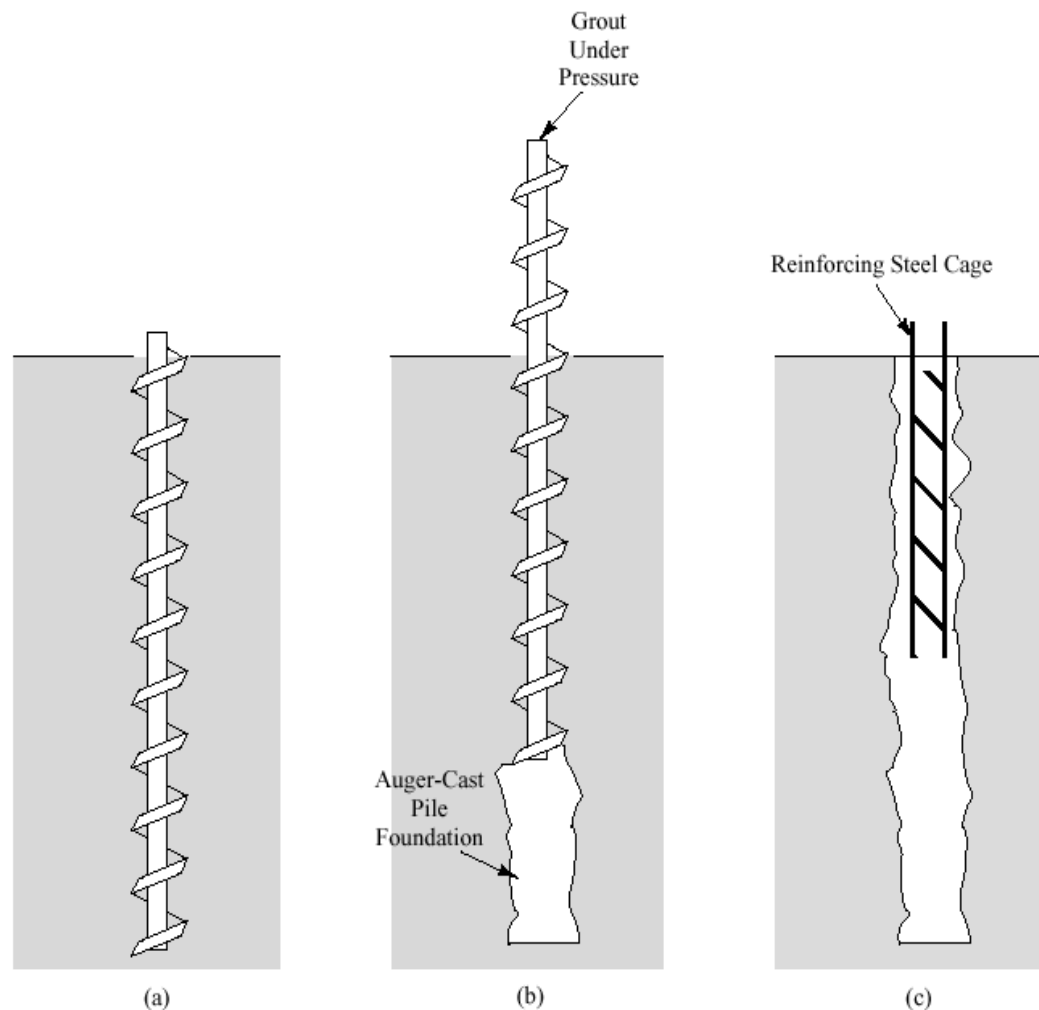

Figure 11.47 Construction of an auger-cast pile: (a) Drill to the required depth using a hollow-stem auger; (b) Withdraw the auger while injecting cement grout; (c) Install steel rebars (optional).

Advantages and Disadvantages of Auger-Cast Pile

● Advantages

- Low mobilisation cost
- Low noise and vibration
- Auger protects the hole from caving
- Grout is injected under pressure, so there is good soil bond and some soil compaction
- Used in a wide variety of soils

● Disadvantages

- Must have good contractor quality control and skills
- Auger can draw up more soil than it should under some conditions
- If equipment breaks down, pile is lost
- Cannot be used with cobbles and boulders
- No check on capacity

Pressure-Injected Footings (Franki Piles)

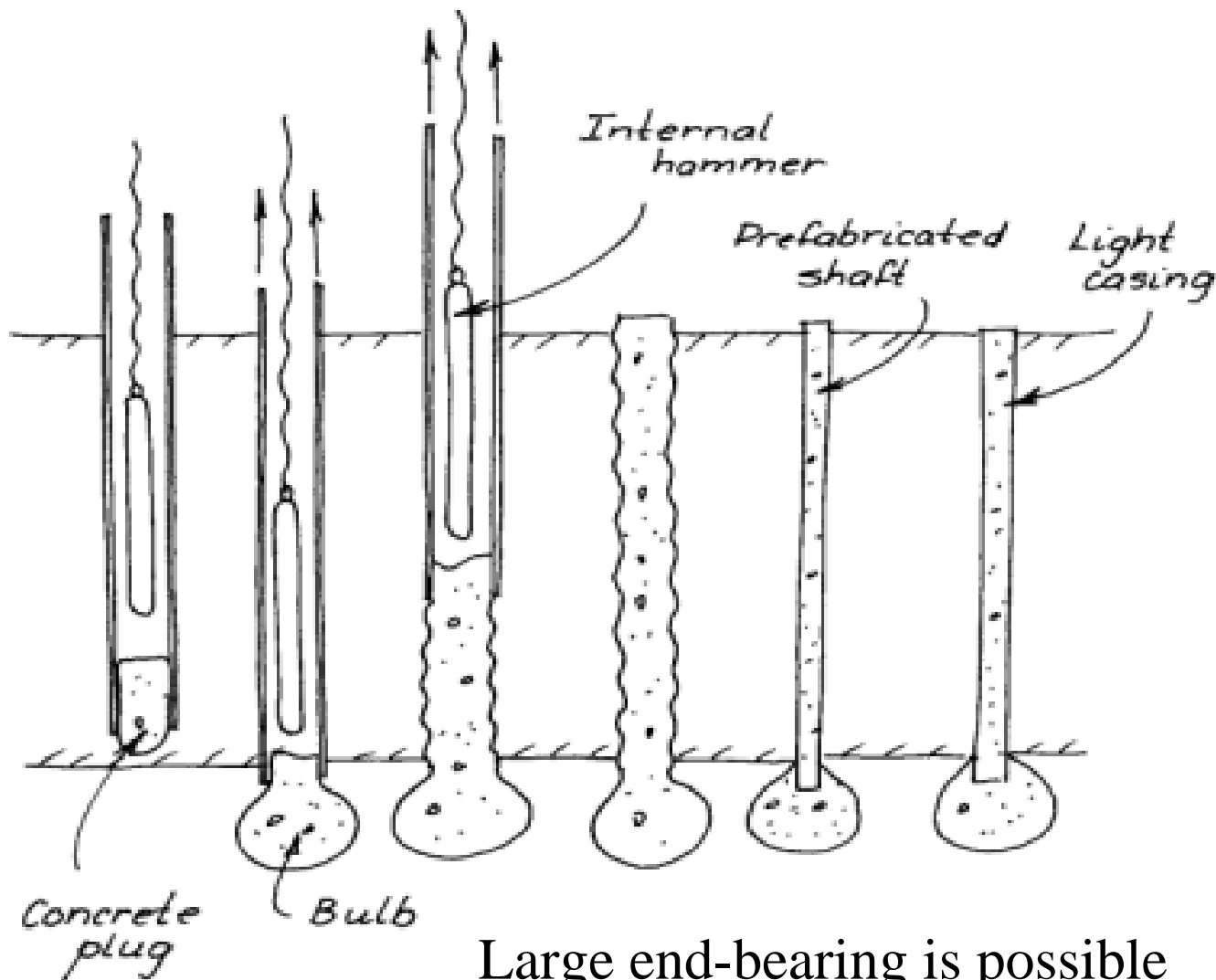

Large end-bearing is possible

Applications of Drilled Shafts

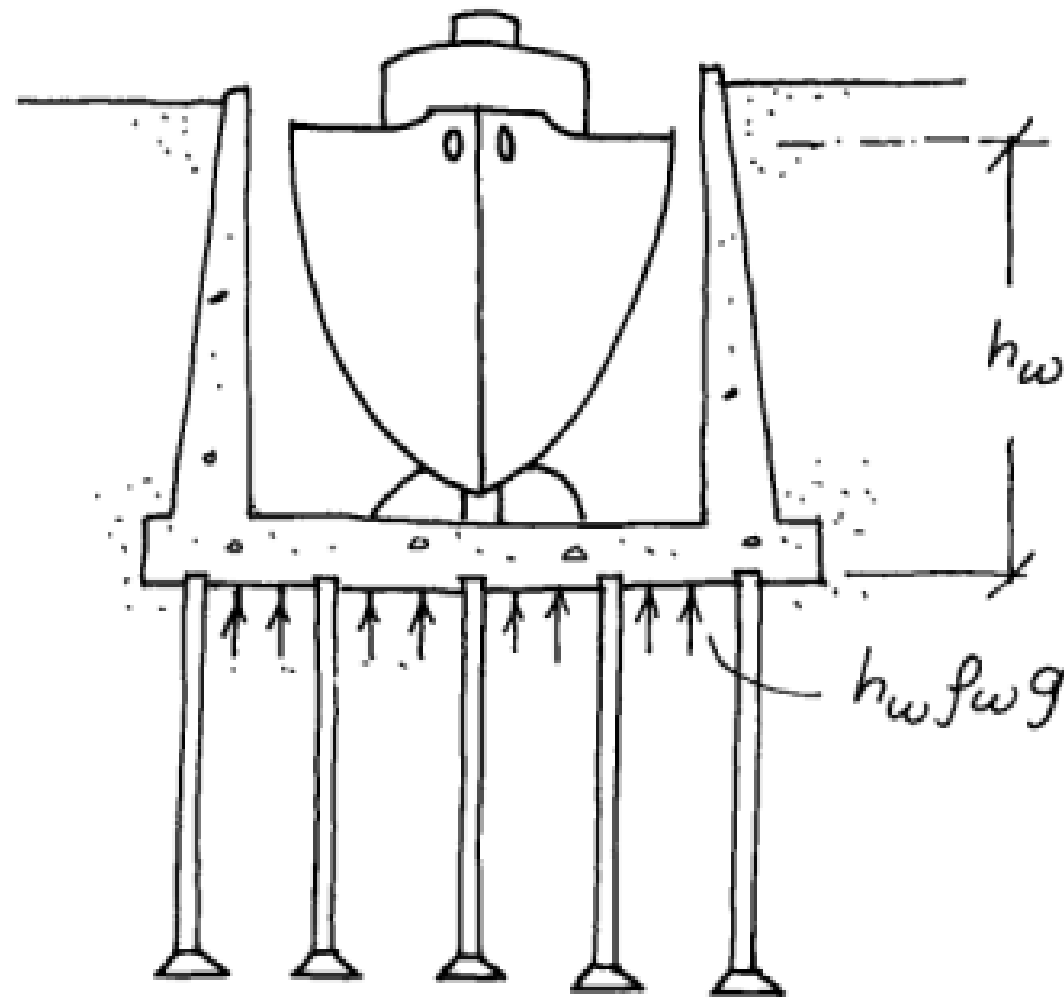

Dry docks
Subway stations

Applications of Drilled Shafts

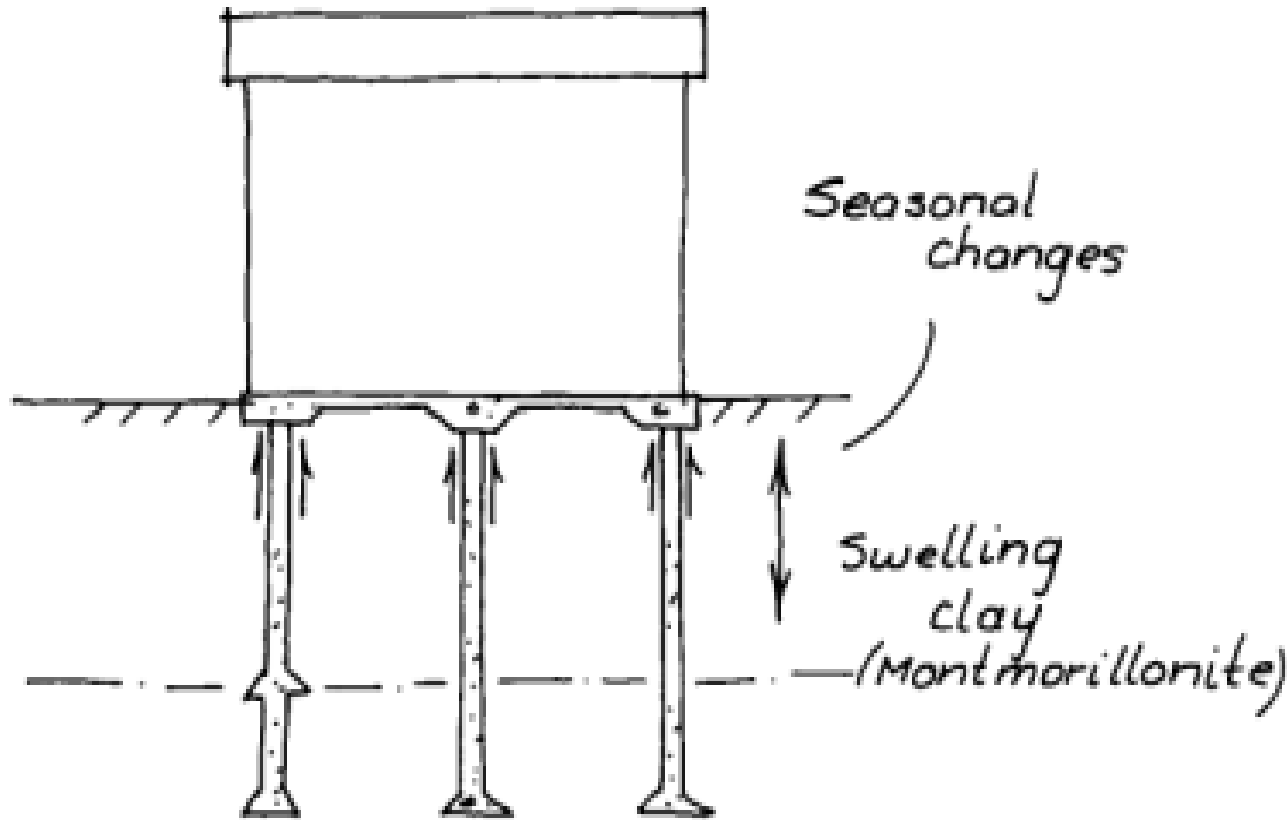

India: Black cotton soil

Texas: Beaumont clay

High w_L , I_p

Other Geotechnical Resources

- <http://www.vulcanhammer.net/utc/>
 - Lectures from previous ENCE 361/461 courses, plus access to a wide variety of geotechnical and marine/aviation/transportation material
- <http://www.vulcanhammer.info/>
 - The website for Vulcan Iron Works, which made pile driving equipment for more than a century
- <http://www.lulu.com/vulcanhammer>
 - Books and CD's on marine and geotechnical engineering